



**ITR 16.21**  
ARTICOLATA



**ITRunner**



[www.itrunner.it](http://www.itrunner.it)

## RIMORCHIO 2 ASSI ITR 16.21

ARTICOLATO  
SOSPENSIONI MECCANICHE

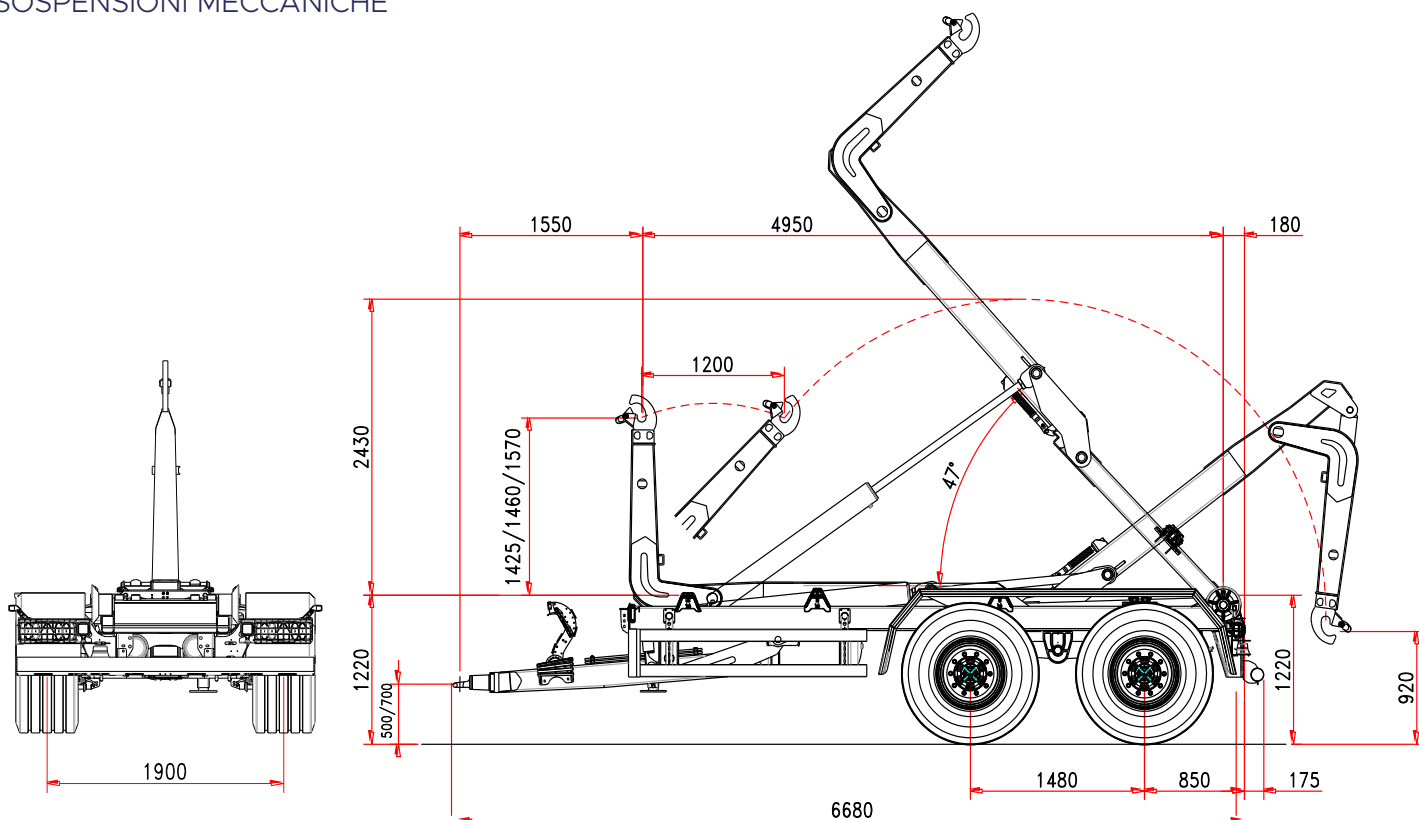

## Caratteristiche Standard

### TELAIO

Sezione longheroni	200 x 100 mm
Timone ammortizzato	silent blocks
Sospensione meccanica (tandem)	21 t
Passo assali	1480 mm
Sezioni assali	2 x 110 mm
Assali	fisso+fisso
Carreggiata	2000 mm
Freni a tamburo	400 x 80 mm
Frenatura	idraulica
Occhione di traino	girevole
Piedino di appoggio	idraulico
Sezione ruote	500/60 R22,5
Altezza piano di carico	1220 mm

### PESO E MISURE

P.T.T. (G.T.W.)	21 t
Dimensione Min./Max cassone	4000/6000 mm
Max velocità	40 km/h
(*) Tara	4680 kg

### BRACCIO ARTICOLATO

Corsa	1200 mm
Altezza gancio	1425/1460/1570
Bloccaggio container esterno	idraulico
Angolo di ribaltamento	47°
Max cap. ribaltamento	16 t
Max cap. carico	16 t

### SISTEMA IDRAULICO

Idraulica al trattore	3 elementi d.e.
Volume olio allestimento	45 l
Volume olio operativo:	
Ribaltamento	8 l
Carico/Scarico	9,3 l

(\*) la tara è riferita all'attrezzatura base del rimorchio senza opzioni ed accessori.

**ITRunner**

**ITR16.21**





**ITRunner**

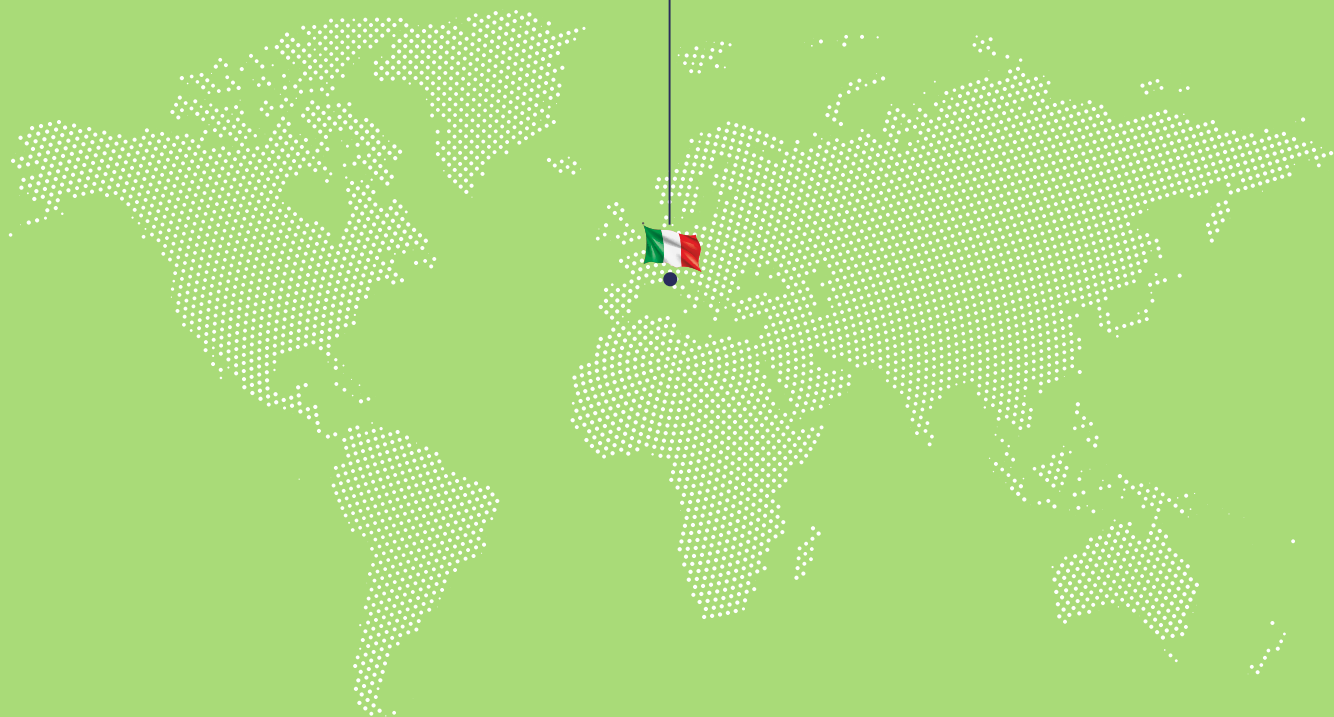

# **ITRunner**

Reg. Oltre Rea, 32  
12060 Monchiero (CN) - Italy  
Phone +39 0173 780 002  
Fax +39 0173 780 700  
Email: info@itranner.it

[www.itrunner.it](http://www.itrunner.it)



*lift your life*

