



ITR 18.23
ARTICOLATA



ITRunner



www.itrunner.it

RIMORCHIO 2 ASSI ITR 18.23
ARTICOLATO
SOSPENSIONI MECCANICHE

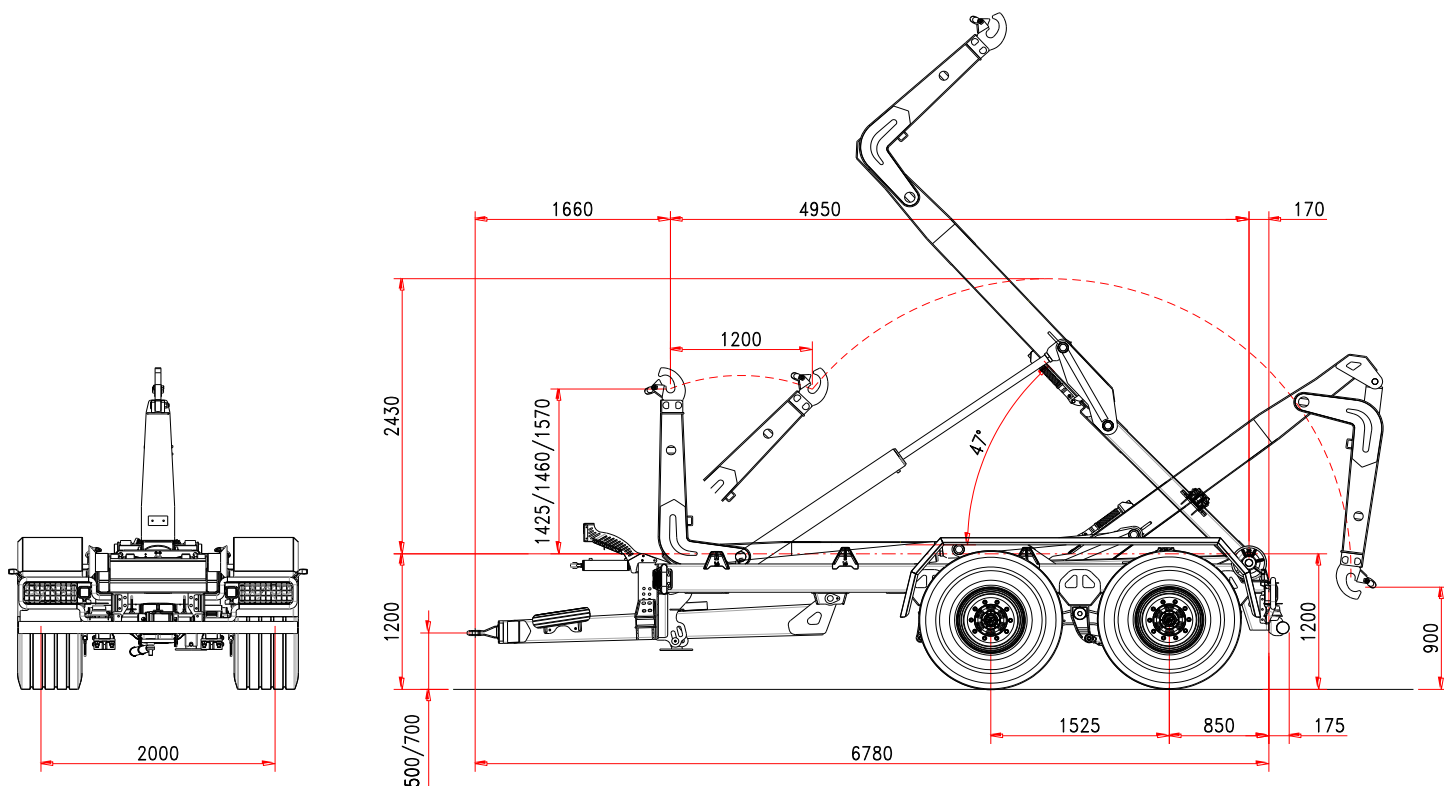

Caratteristiche Standard

TELAIO

Sezione longheroni	250 x 100 mm
Timone ammortizzato	silent blocks
Sospensione meccanica (tandem)	24 t
Passo assali	1525 mm
Sezioni assali	2 x 110 mm
Assali	fisso+fisso
Carreggiata	2000 mm
Freni a tamburo	406 x 120
Frenatura	idraulica
Occhione di traino	girevole
Piedino di appoggio	idraulico
Sezione ruote	550/60 R22,5
Altezza piano di carico	1200 mm
Stabilizzazione al 3° punto	standard

PESO E MISURE

P.T.T. (G.T.W.)	23 t
Dimensione Min./Max cassone	4000/6000 mm
Max velocità	40 km/h
(*) Tara	5100 kg

BRACCIO ARTICOLATO

Corsa	1200 mm
Altezza gancio	1425/1460/1570
Bloccaggio container esterno	idraulico
Angolo di ribaltamento	47°
Cilindro spunto	standard
Max cap. ribaltamento	18 t
Max cap. carico	18 t

SISTEMA IDRAULICO

Idraulica al trattore	3 elementi d.e.
Volume olio allestimento	46 l
Volume olio operativo:	
Ribaltamento	11,4 l
Carico/Scarico	12,7 l
3 elettrovalvole con comando Bobeasy base	

(*) la tara è riferita all'attrezzatura base del rimorchio senza opzioni ed accessori.

ITRunner

ITR 18.23
ARTICOLATA





ITRunner

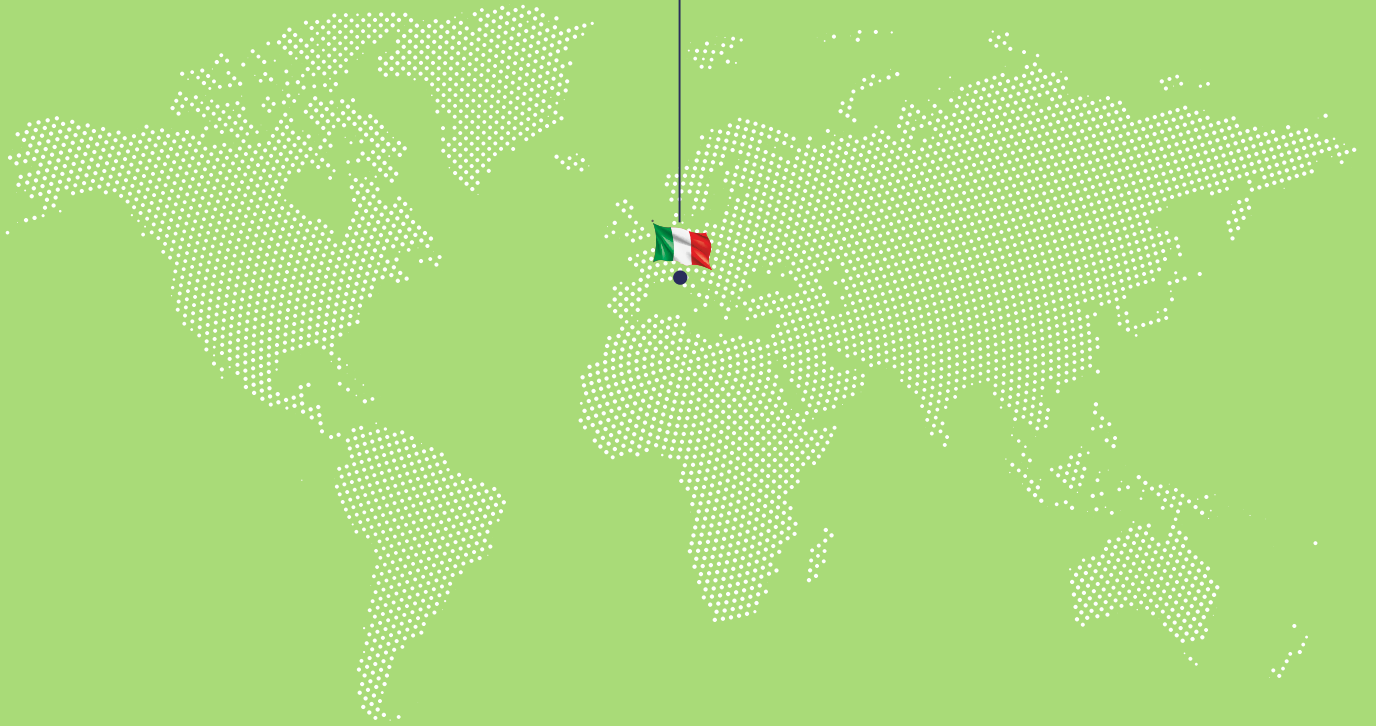

ITRunner

Reg. Oltre Rea, 32
12060 Monchiero (CN) - Italy
Phone +39 0173 780 002
Fax +39 0173 780 700
Email: info@itranner.it

www.itrunner.it



lift your life