



# ITR 16.21

KNICKARM



**ITRunner**



[www.itrunner.it](http://www.itrunner.it)

## HAKENLIFTANHÄNGER ITR 16.21

KNICKARM  
MECHANISCHE FEDERUNG

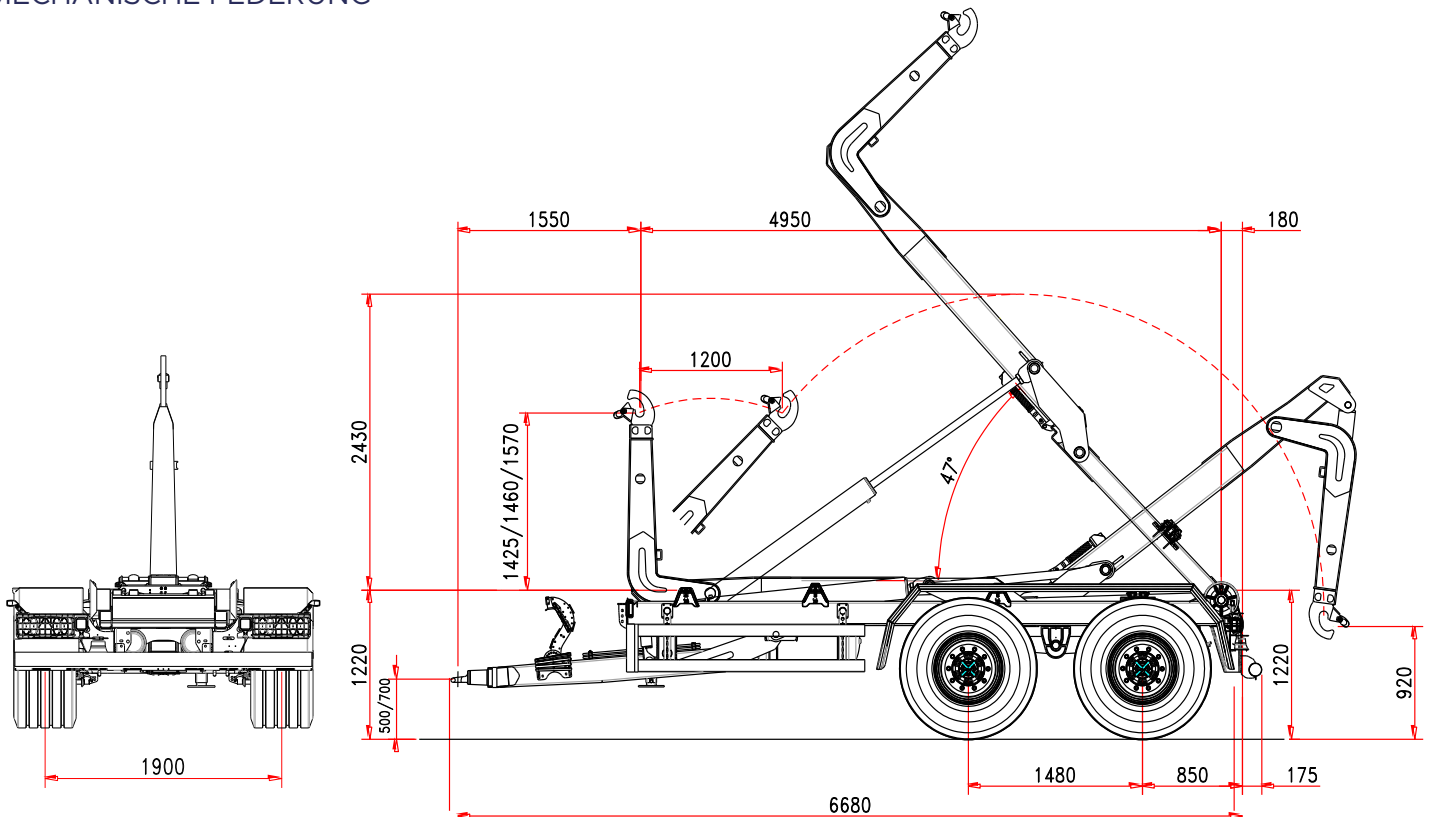

## Standard-Merkmale

### FAHRGESTELL

Rahmenquerschnitt	200 x 100 mm
Deichselfederung	silent block
Tragfähigkeit (tandem)	21 t
Achsenabstand	1480 mm
Achsenquerschnitt	2 x 110 mm
Achsen	fest+fest
Wagenspur	2000 mm
Bremstrommel	400 x 80 mm
Bremssystem	hydraulisch
Zugöse	fest
Stützfuß	hydraulisch
Bereifung	500/60-22,5
Ladehöhe	1220 mm

### MASSE UND GEWICHT

Gesamtgewicht	21 t
Containerlänge min./max	4000/6000 mm
Zul.Höchstgeschwindigkeit	40 km/h
(*) Leergewicht	4680 kg

### KNICKARM

Bewegung	1200 mm
Hakenhöhe	1425/1460/1570
Innere/äußere	
Containerverriegelung	hydraulisch
Kippwinkel	47°
Hilfszylinder	standard
kippkapazität	16 t
Hebekapazität	16 t

### HIDRAULIKANLAGE

Hydraulik am Traktor	3 doppelwirkende
Ölbedarf (Hakenlift gefüllt)	Steuerelemente
Ölbedarf in den Zylindern:	45 l
Kippen	8 l
Laden/Absetzen	9,3 l

(\*) Leergewicht ohne Zusatzausstattungen und Sonderausrüstungen



**ITRunner**

**ITR 16.21**  
KNICKARM





**ITRunner**

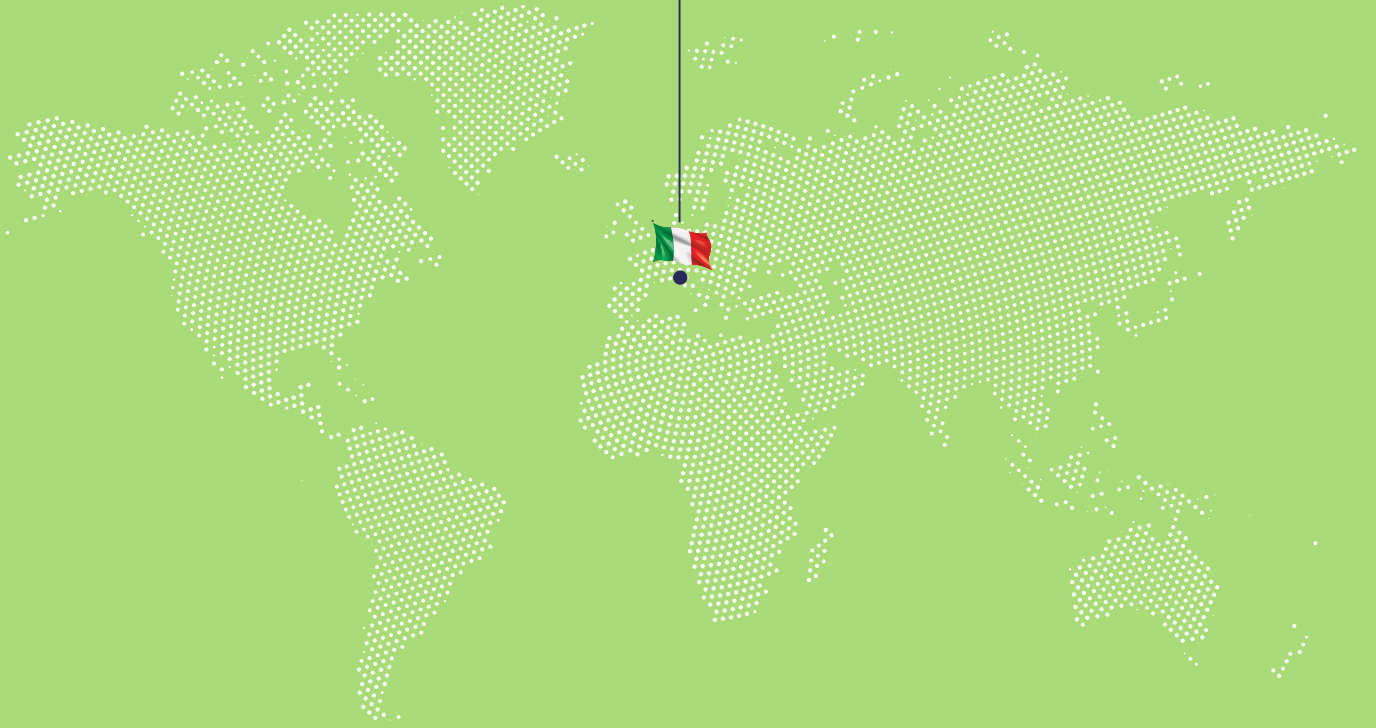

# **ITRunner**

Reg. Oltre Rea, 32  
12060 Monchiero (CN) - Italy  
Phone +39 0173 780 002  
Fax +39 0173 780 700  
Email: info@itranner.it

[www.itrunner.it](http://www.itrunner.it)



*lift your life*