



ITR 18.23

KNICKARM



ITRunner



www.itrunner.it

HAKENLIFTANHÄNGER ITR 18.23

KNICKARM
MECHANISCHE FEDERUNG

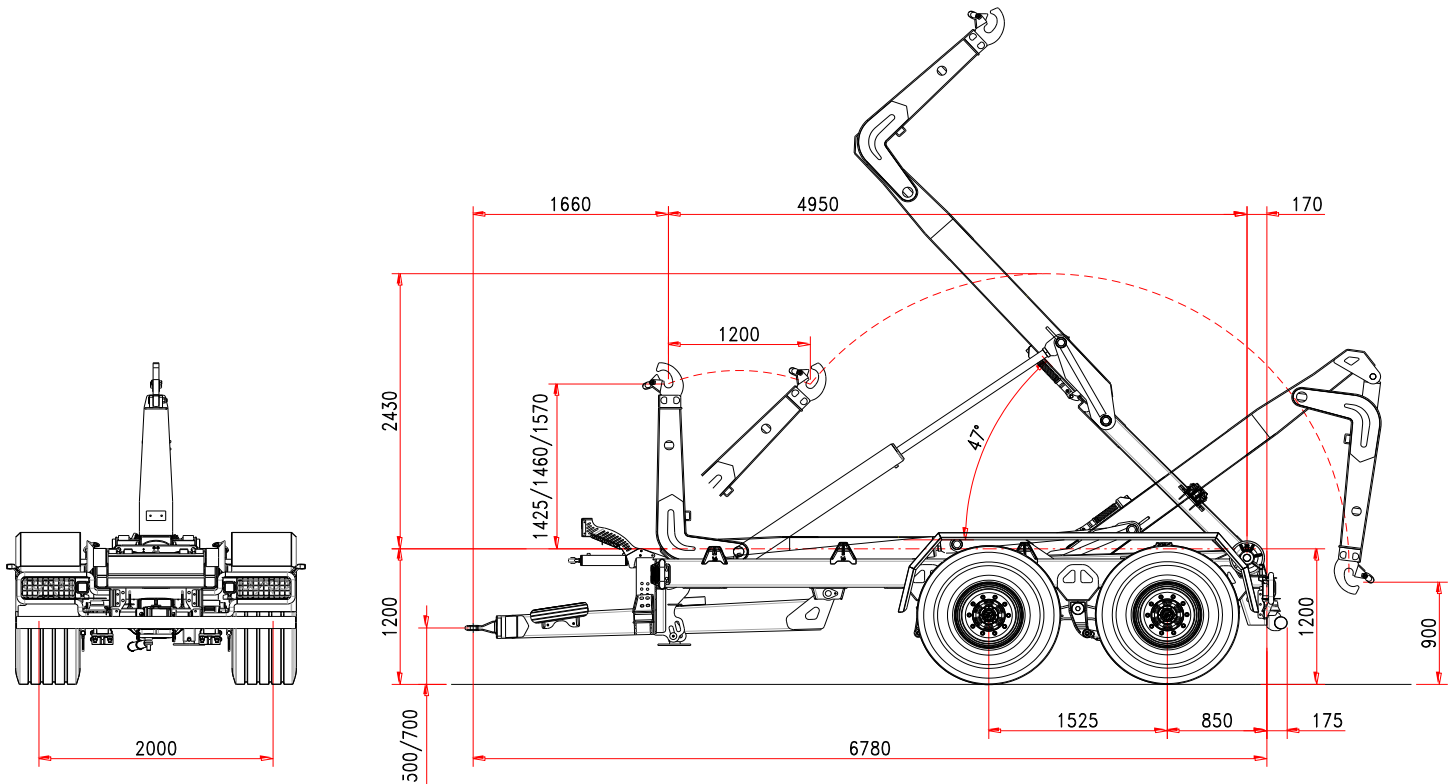

Standard-Merkmale

FAHRGESTELL

Rahmenquerschnitt	250 x 100 mm
Deichselfederung	silent blocks
Tragfähigkeit (tandem)	24 t
Achsenabstand	1525 mm
Achsenquerschnitt	2 x 110 mm
Achsen	fest+fest
Wagenspur	2000 mm
Bremstrommel	406 x 120 mm
Bremssystem	hydraulisch
Zugöse	drehbar
Stützfuß	hydraulisch
Bereifung	500/60-22,5
Ladehöhe	1200 mm
Stützzyylinder am 3.Punkt	standard

MASSE UND GEWICHT

Gesamtgewicht	23 t
Containerlänge min./max	4000/6000 mm
Zul.Höchstgeschwindigkeit	40 km/h
(*) Leergewicht	5100 kg

KNICKARM

Bewegung	1200 mm
Hakenhöhe	1425/1460/1570
Innere/äußere	
Containerverriegelung	hydraulisch
Kippwinkel	47°
Hilfszylinder	standard
kippkapazität	18 t
Hebekapazität	18 t

HIDRAULIKANLAGE

Hydraulik am Traktor	3 doppelwirkende
	Steuerelemente
Ölbedarf (Hakenlift gefüllt)	46 l
Ölbedarf in den Zylindern:	
Kippen	11,4 l
Laden/Absetzen	12,7 l
3 Magnetventile mit Bobeasy-Basis	

(*) Leergewicht ohne Zusatzausstattungen und Sonderausrüstungen

ITRunner

ITR 18.23
KNICKARM





ITRunner

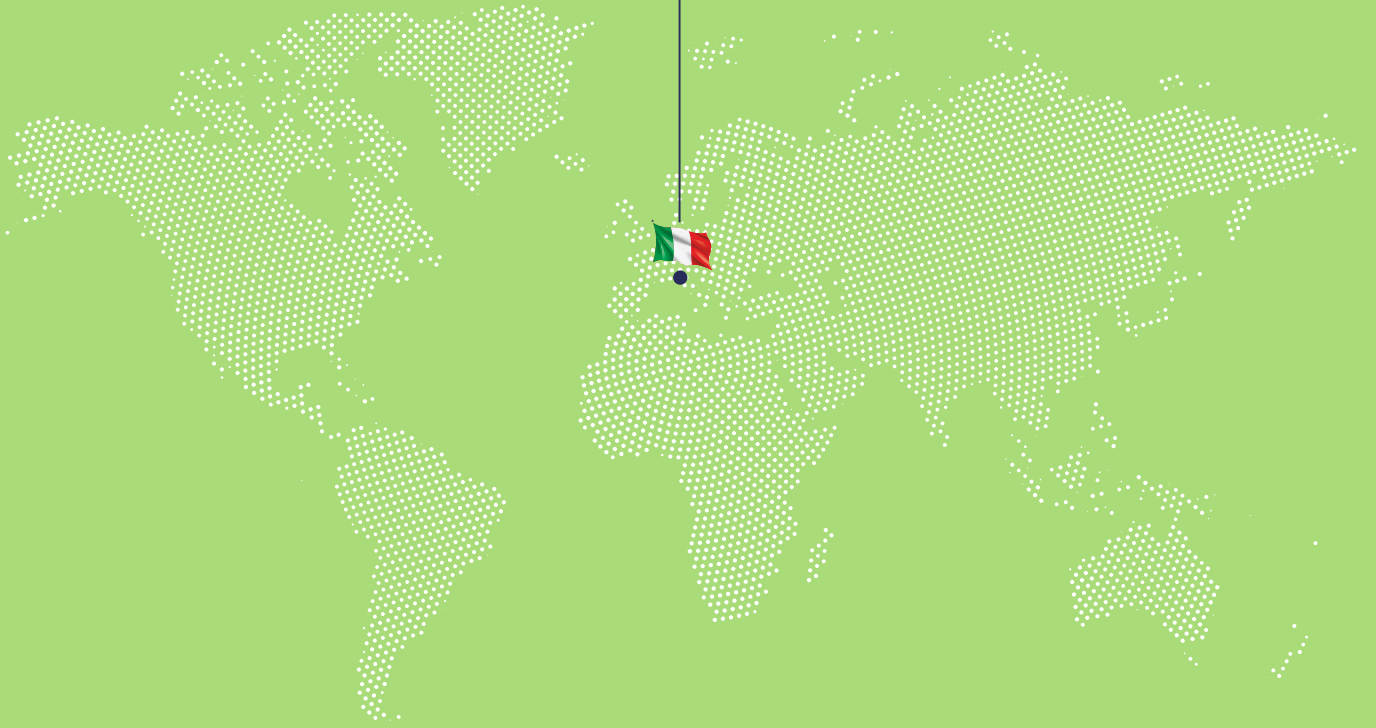

ITRunner

Reg. Oltre Rea, 32
12060 Monchiero (CN) - Italy
Phone +39 0173 780 002
Fax +39 0173 780 700
Email: info@itranner.it

www.itrunner.it



lift your life