



ITR 18.23/6H

ARTICULATED



ITRunner



www.itrunner.it

2 AXLES HOOKLIFT TRAILER ITR 18.23/6H

ARTICULATED
HYDRAULIC SUSPENSIONS

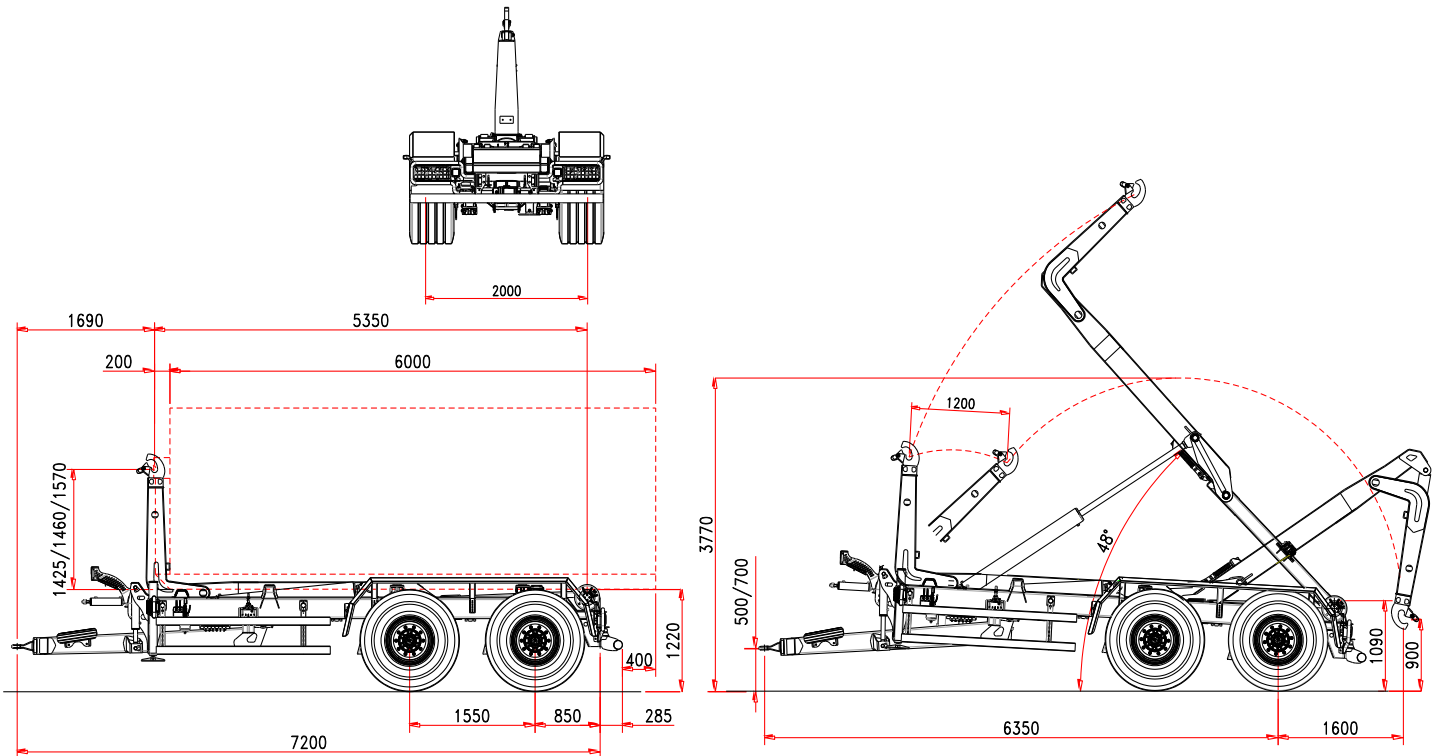

Standard Features

CHASSIS

Frame section	250 x 100 mm
Draw bar	hydraulic
Leaf spring suspension	24 t
Axles wheelbase	1550 mm
Axles section	2 x 150 mm
Axles	fixed + fixed
Track	2000 mm
Brake drums	406 x 120 mm
Braking system	hydraulic
Towing eye	turning
Support foot	hydraulic
Wheel size	550/60 R22,5
Chassis loading level	1220 mm
3 rd point hydraulic stab. cylinder	standard

WEIGHT AND DIMENSION

Gross Trailer Weight (G.T.W.)	23 t
Container handling cap.	4500/6200 mm
Max speed	40 km/h
(*) Tare	5400 kg

ARTICULATED ARM

Run	1200 mm
Hook level	1425/1460/1570
Container internal/external locking	hydraulic
Tipping angle	48°
Hoist start cylinder	standard
Tipping capacity	18 t
Lifting capacity	18 t

OLEO-DYNAMIC SYSTEM

Tractor hydraulics	4 controls d.e.
Oil volume (hooklift filled)	47 l
Hooklift filled:	
Cylinders oil operation demand	
Tipping	11,4 l
Loading/unloading	12,7 l
3 sections electro-valves with control Bobeasy base	

(*) Tare: the trailer weight is referred to the basic unit without options and accessories.

ITRunner

ITR 18.23/6H
ARTICULATED





ITRunner

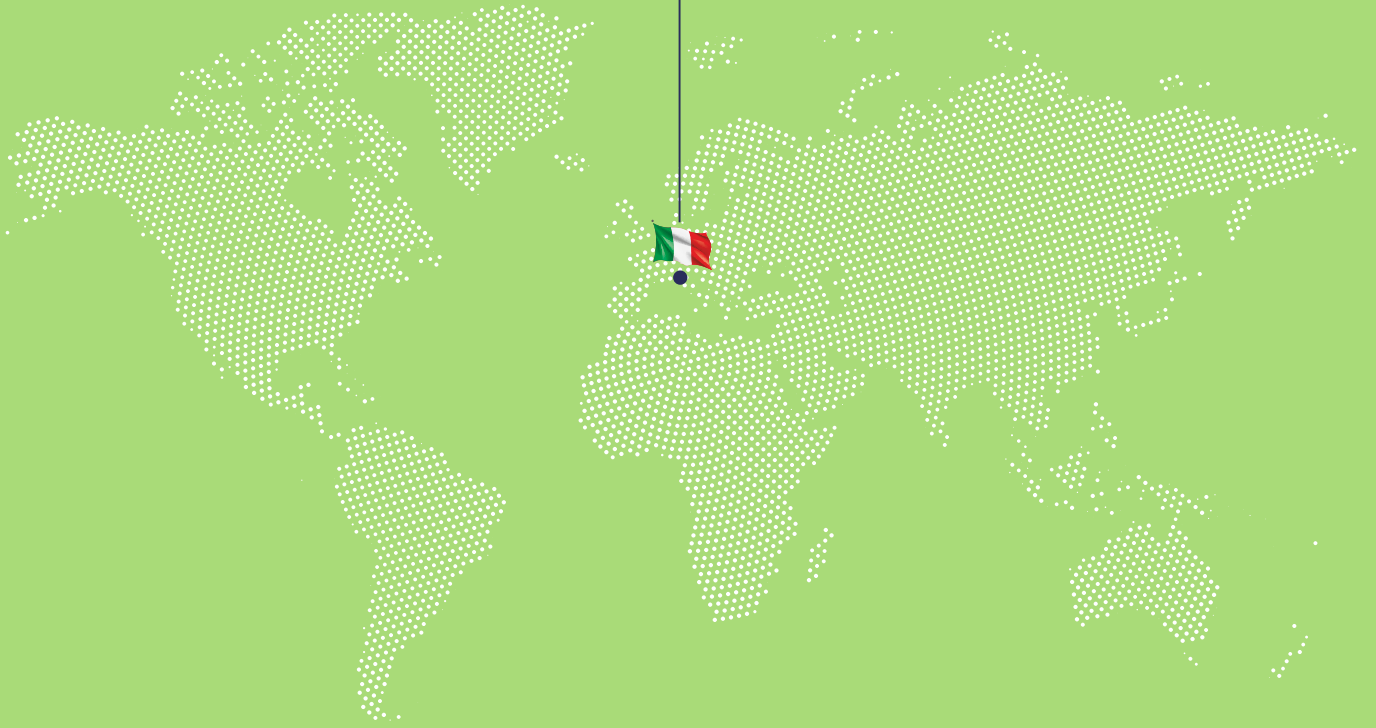

ITRunner

Reg. Oltre Rea, 32
12060 Monchiero (CN) - Italy
Phone +39 0173 780 002
Fax +39 0173 780 700
Email: info@itranner.it

www.itrunner.it



lift your life