



# ITRK 33.34HD

TELESCOPIC ARTICULATED



**ITRunner**



[www.itrunner.it](http://www.itrunner.it)

**3 AXLES HOOKLIFT ITRK 30.34 HD**  
TELESCOPIC AND ARTICULATED  
HYDRAULIC SUSPENSIONS

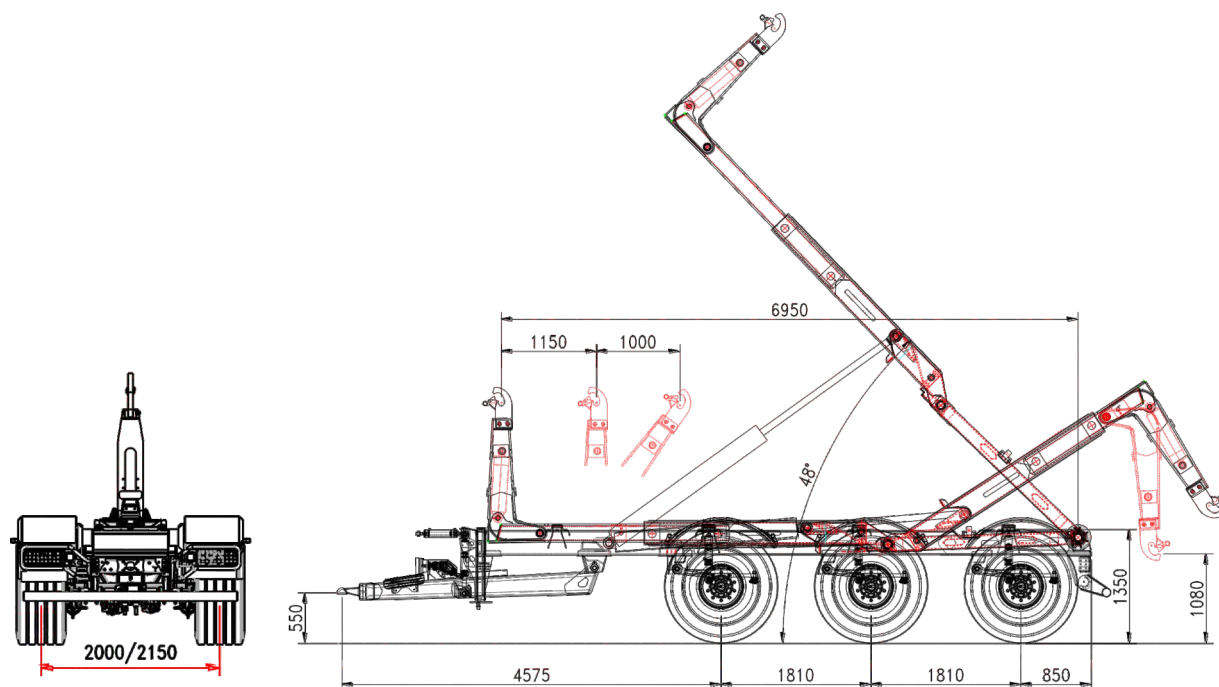

## Standard Features

### CHASSIS

Frame section	300 x 100 mm
Draw bar	hydraulic
Suspension hydraulic	36 t
Axles wheelbase	1810 mm
Axles section	3 x 150 mm
Axles	fixed+fixed+fixed
Track	2000 mm
Brake drums	406 x 120
Braking system	hydraulic
Towing eye	turning
Support foot	2xhydraulic
Wheel size	550/60 R22,5
Chassis loading level	1350 mm
Front stab. Cylinder 3 <sup>rd</sup> point	standard

### WEIGHT AND DIMENSION

Gross Trailer Weight (G.T.W.)	33/34 t
Container handling cap.	5500/8200 mm
Max speed	40 km/h
(*) Tare	8600 kg

### TELESCOPIC AND ARTICULATED ARM

Run	1150 + 1000 mm
Hook level	1425/1460/1570
Container internal/external locking	hydraulic
Tipping angle	48°
Hoist start cylinder	standard
Tipping capacity	30 t
Lifting capacity	30 t

### OLEO-DYNAMIC SYSTEM

Tractor hydraulics	2 controls d.a.
Trailer hydraulics:	
Cardan + piston pump	108 lt/1000 rpm
Oil tank	160 lt
Flow control electro-hydraulic with ground manual levers and remote radio control Bobeasy	

(\*) Tare: the trailer weight is referred to the basic unit without options and accessories.



**ITRunner**

**ITRK 33.34HD**  
TELESCOPIC ARTICULATED







**ITRunner**

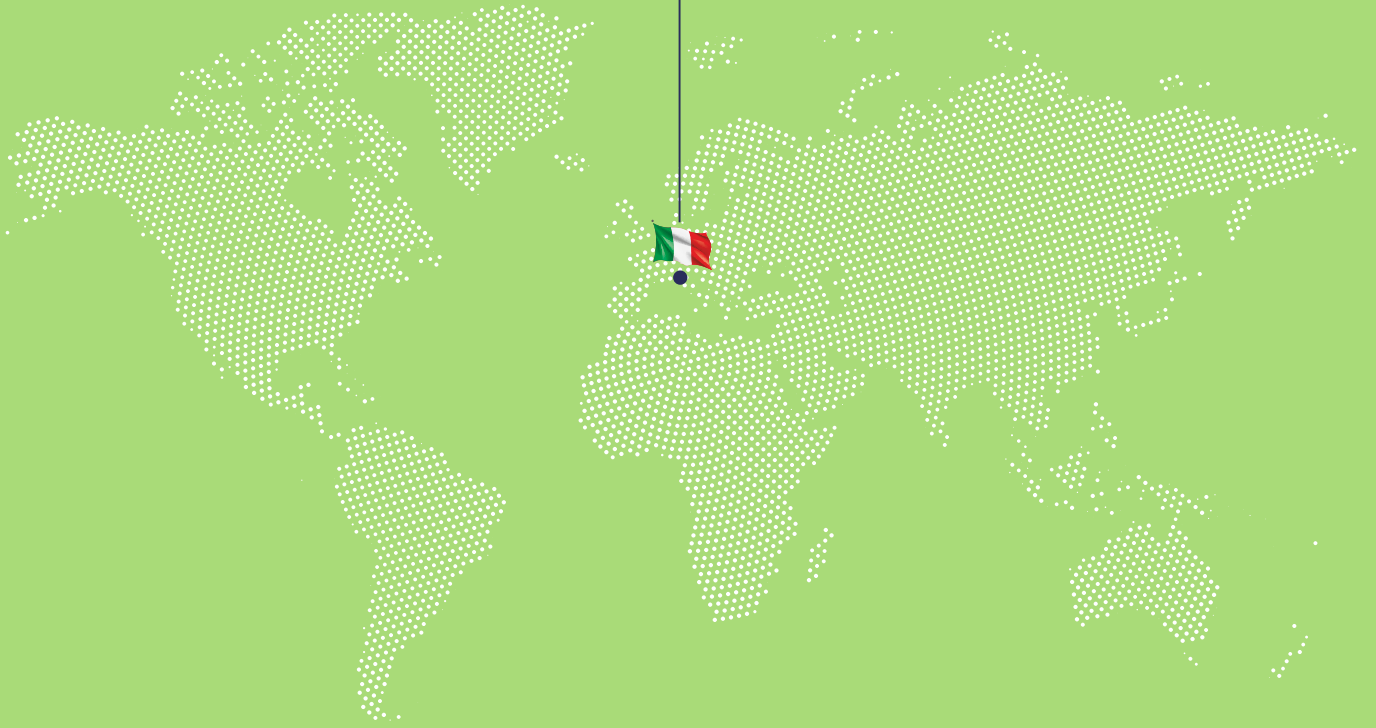

# **ITRunner**

Reg. Oltre Rea, 32  
12060 Monchiero (CN) - Italy  
Phone +39 0173 780 002  
Fax +39 0173 780 700  
Email: info@itranner.it

[www.itrunner.it](http://www.itrunner.it)



*lift your life*