



RIMORCHIO 2 ASSI ITR 10.16
ARTICOLATO - SOSPENSIONI MECCANICHE

2 AXLES HOOKLIFT TRAILER ITR 10.16
ARTICULATED - MECHANIC SUSPENSIONS

REMORQUE 2 ESSIEUX ITR 10.16
ARTICULÉ - SUSPENSION MÉCANIQUE

HAKENLIFTANHÄNGER ITR 10.16
KNICKARM - MECHANISCHE FEDERUNG

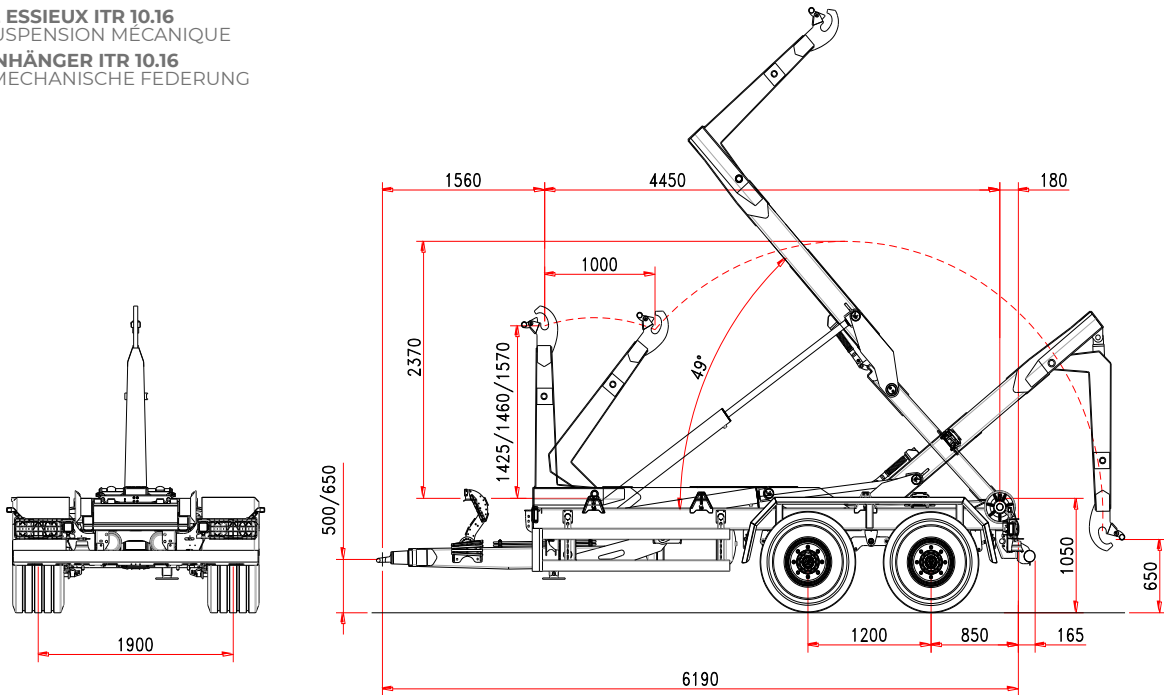

Caratteristiche Standard

Standard Features

Caractéristiques Standard

Standard-Merkmale

TELAIO

	Sezione longheroni	200 x 100 mm
	Sezioni assali	2 x 100 mm
	Freni a tamburo	350 x 90 mm
	Sezione ruote	500/50-17

PESO E MISURE

P.T.T. (G.T.W.)	16 t
Dimensione Min./Max cassone	3500/5500 mm
Max velocità	40 km/h
(*) Tara	3500 kg

BRACCIO ARTICOLATO

Altezza gancio	1425/1460/1570
Bloccaggio container esterno	idraulico
Angolo di ribaltamento	49°
Max cap. ribaltamento	10 t
Max cap. carico	10 t

SISTEMA IDRAULICO

Idraulica al trattore	3 elementi d.e.
-----------------------	-----------------

(*) la tara è riferita all'attrezzatura base del rimorchio senza opzioni ed accessori

CHASSIS

	Section structure	200 x 100 mm
	Section essieux	2 x 100 mm
	Freins tambour	350 x 90 mm
	Pneus	500/50-17

POIDS ET DIMENSIONS

Poids totale remorque	16 t
Longueur conteneur	3500/5500 mm
Max vitesse	40 km/h
(*) Tara	3500 kg

BRAS ARTICULE

Hauteur crochet	1425/1460/1570
Verrouillage conteneur	hydraulique
Angle de bennage	49°
Max capacité de bennage	10 t
Max capacité de charge	10 t

SYSTÈME HYDRAULIQUE

Hydraulique tracteur	3 contrôles d.e.
----------------------	------------------

(*) La tare de la remorque est référencé à l'équipement base sans options et accessoires.

CHASSIS

	Frame section	200 x 100 mm
	Axles section	2 x 100 mm
	Brake drums	350 x 90 mm
	Wheel size	500/50-17

WEIGHT AND DIMENSION

Gross Trailer Weight (G.T.W.)	16 t
Container handling cap.	3500/5500 mm
Max speed	40 km/h
(*) Tare	3500 kg

ARTICULATED ARM

Hook level	1425/1460/1570
Container internal/external locking	hydraulic
Tipping angle	49°
Tipping capacity	10 t
Lifting capacity	10 t

OLEO-DYNAMIC SYSTEM

Tractor hydraulics	3 controls d. a.
--------------------	------------------

(*) Tare: the trailer weight is referred to the basic unit without options and accessories.

FAHRGESTELL

	Rahmenquerschnitt	200 x 100 mm
	Achsenquerschnitt	2 x 100 mm
	Bremstrommel	350 x 90 mm
	Bereifung	500/50-17

MASSE UND GEWICHT

Gesamtgewicht	16 t
Containerlänge min./max	3500/5500 mm
Zul.Höchstgeschwindigkeit	40 km/h
(*) Leergewicht	3500 kg

KNICKARM

Hakenhöhe	1425/1460/1570
Innere/äußere Containerverriegelung	hydraulisch
Kippwinkel	49°
kippkapazität	10 t
Hebekapazität	10 t

HIDRAULIKANLAGE

Hydraulik am Traktor	3 doppelwirkende Steuerelemente
----------------------	---------------------------------

(*) Leergewicht ohne Zusatzausstattungen und Sonderausrüstungen