

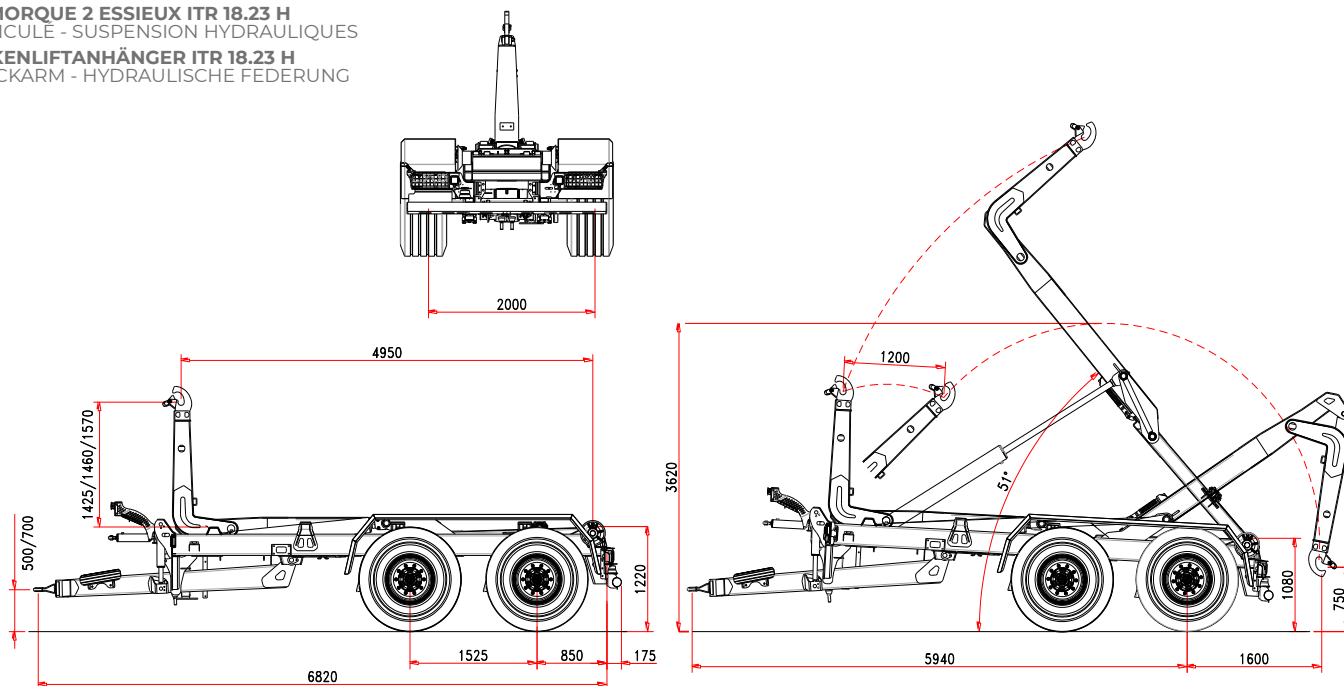

**RIMORCHIO 2 ASSI ITR 18.23 H**  
ARTICOLATO - SOSPENSIONI IDRAULICHE  
**2 AXLES HOOKLIFT TRAILER ITR 18.23 H**  
ARTICULATED - HYDRAULIC SUSPENSIONS

**REMORQUE 2 ESSIEUX ITR 18.23 H**  
ARTICULÉ - SUSPENSION HYDRAULIQUES

**HAKENLIFTAHÄNGER ITR 18.23 H**  
KNICKARM - HYDRAULISCHE FEDERUNG



## Caratteristiche Standard

## Standard Features

## Caractéristiques Standard

## Standard-Merkmale

### TELAIO

	Sezione longheroni	250 x 100 mm
	Sezioni assali	2 x 150 mm
	Freni a tamburo	406 x 120 mm
	Sezione ruote	550/60-22,5

### PESO E MISURE

P.T.T. (G.T.W.)	23 t
Dimensione Min./Max cassone	4000/6000 mm
Max velocità	40 km/h
(*) Tara	5200 kg

### BRACCIO ARTICOLATO

Altezza gancio	1425/1460/1570
Bloccaggio container esterno	idraulico
Angolo di ribaltamento	51°
Max cap. ribaltamento	18 t
Max cap. carico	18 t

### SISTEMA IDRAULICO

Idraulica al trattore	4 elementi d.e.
-----------------------	-----------------

(\*) la tara è riferita all'attrezzatura base del rimorchio senza opzioni ed accessori

### CHASSIS

	Section structure	250 x 100 mm
	Section essieux	2 x 150 mm
	Freins tambour	406 x 120 mm
	Pneus	550/60-22,5

### POIDS ET DIMENSIONS

Poids totale remorque	23 t
Longueur conteneur	4000/6000 mm
Max vitesse	40 km/h
(*) Tara	5200 kg

### BRAS ARTICULE

Hauteur crochet	1425/1460/1570
Verrouillage conteneur	hydraulique
Angle de bennage	51°
Max capacité de bennage	18 t
Max capacité de charge	18 t

### SYSTÈME HYDRAULIQUE

Hydraulique tracteur	4 contrôles d.e.
----------------------	------------------

(\*) La tare de la remorque est référencé à l'équipement base sans options et accessoires.

### CHASSIS

	Frame section	250 x 100 mm
	Axles section	2 x 150 mm
	Brake drums	406 x 120 mm
	Wheel size	550/60-22,5

### WEIGHT AND DIMENSION

Gross Trailer Weight (G.T.W.)	23 t
Container handling cap.	4000/6000 mm
Max speed	40 km/h
(*) Tare	5200 kg

### ARTICULATED ARM

Hook level	1425/1460/1570
Container internal/external locking	hydraulic
Tipping angle	51°
Tipping capacity	18 t
Lifting capacity	18 t

### OLEO-DYNAMIC SYSTEM

Tractor hydraulics	4 controls d. a.
--------------------	------------------

(\*) Tare: the trailer weight is referred to the basic unit without options and accessories.

### FAHRGESTELL

	Rahmenquerschnitt	250 x 100 mm
	Achsenquerschnitt	2 x 150 mm
	Bremstrommel	406 x 120 mm
	Bereifung	550/60-22,5

### MASSE UND GEWICHT

Gesamtgewicht	23 t
Containerlänge min./max	4000/6000 mm
Zul.Höchstgeschwindigkeit	40 km/h
(*) Leergewicht	5200 kg

### KNICKARM

Hakenhöhe	1425/1460/1570
Innere/äußere Containerverriegelung	hydraulisch
Kippwinkel	51°
kippkapazität	18 t
Hebekapazität	18 t

### HIDRAULIKANLAGE

Hydraulik am Traktor	4 doppelwirkende
----------------------	------------------

(\*) Leergewicht ohne Zusatzausstattungen und Sonderausrüstungen