

ITRK *Telescopic Articulated*

*Telescopiche Articolate - Telescopique Articulées
Teleskop Knickarm*



ITRunner

KEEP CALM AND FARM

www.itrunner.it

SP 159

4

bob



Chiabotti Rea

SP 661



Da 45 anni produciamo attrezzature per il trasporto di materiali sviluppando un know how globale in grado di renderci una delle aziende di riferimento a livello internazionale.



For 45 years we have been producing equipment for the transport of materials developing a global know-how able to make us one of the reference companies at international level.



Depuis 45 ans, nous produisons des équipements pour le transport de matériaux développant un savoir-faire mondial capable de faire de nous l'une des sociétés de référence au niveau international



Seit 45 Jahren produzieren wir Anlagen für den Transport von Materialien und entwickeln ein globales Know-how, das uns zu einem der Referenzunternehmen auf internationaler Ebene machen kann

Strada Santa Lucia

DNV
MANAGEMENT SYSTEM CERTIFICATE

Certificate no.: CERT-09968-2001-AQ-TRI-SINCERT Initial certification date: 31 December 2001 Valid: 12 December 2022 - 11 December 2025

This is to certify that the management system of **B.O.B. Sistemi Idraulici S.p.A. - Sede Legale e Operativa**
Regione Oltre Rea, 32 - 12060 Monchiero (CN) - Italy
and the sites as mentioned in the appendix accompanying this certificate
has been found to conform to the Quality Management System standard:
ISO 9001:2015

This certificate is valid for the following scope:
Design, manufacture, trade and assistance of equipment, agricultural hooklift trailers, hooklifts and loaders for industrial and agricultural vehicles (IAF: 18)

Place and date:
Vimercate (MB), 18 November 2022

ACCREDIA
ACCREDITED BODY FOR CERTIFICATION

For the issuing office:
DNV - Business Assurance
Via Energy Park, 14 - 20871 Vimercate (MB) - Italy

Claudia Barocini
Claudia Barocini
Management Representative

Lack of fulfillment of conditions as set out in the Certification Agreement may render this Certificate invalid.
ACCREDITED UNIT: DNV Business Assurance Italy S.r.l., Via Energy Park, 14 - 20871 Vimercate (MB) - Italy - TEL: +39 68 99 905 - www.dnv.it

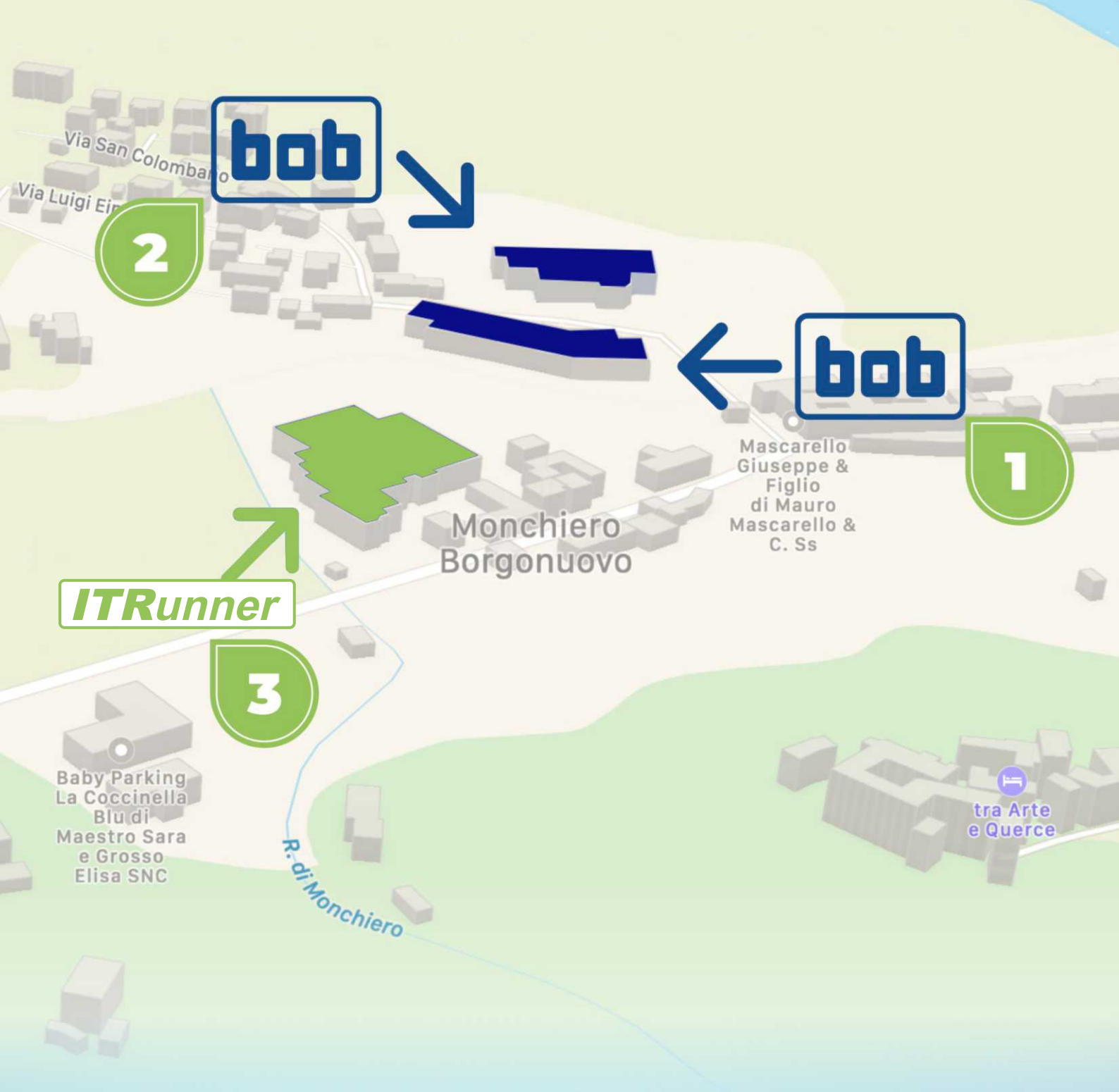



RIMORCHIO 2 ASSI ITRK 16.21
TELESCOPICO ARTICOLATO - SOSPENSIONI MECCANICHE
2 AXLES HOOKLIFT TRAILER ITRK 16.21
TELESCOPIC ARTICULATED - MECHANIC SUSPENSIONS
REMORQUE 2 ESSIEUX ITRK 16.21
TELESCOPIQUE ARTICULÉ - SUSPENSIONS MECANQUES
HAKENLIFTANHÄNGER ITRK 16.21
TELESKOPKNICKARM - MECHANISCHE FEDERUNG

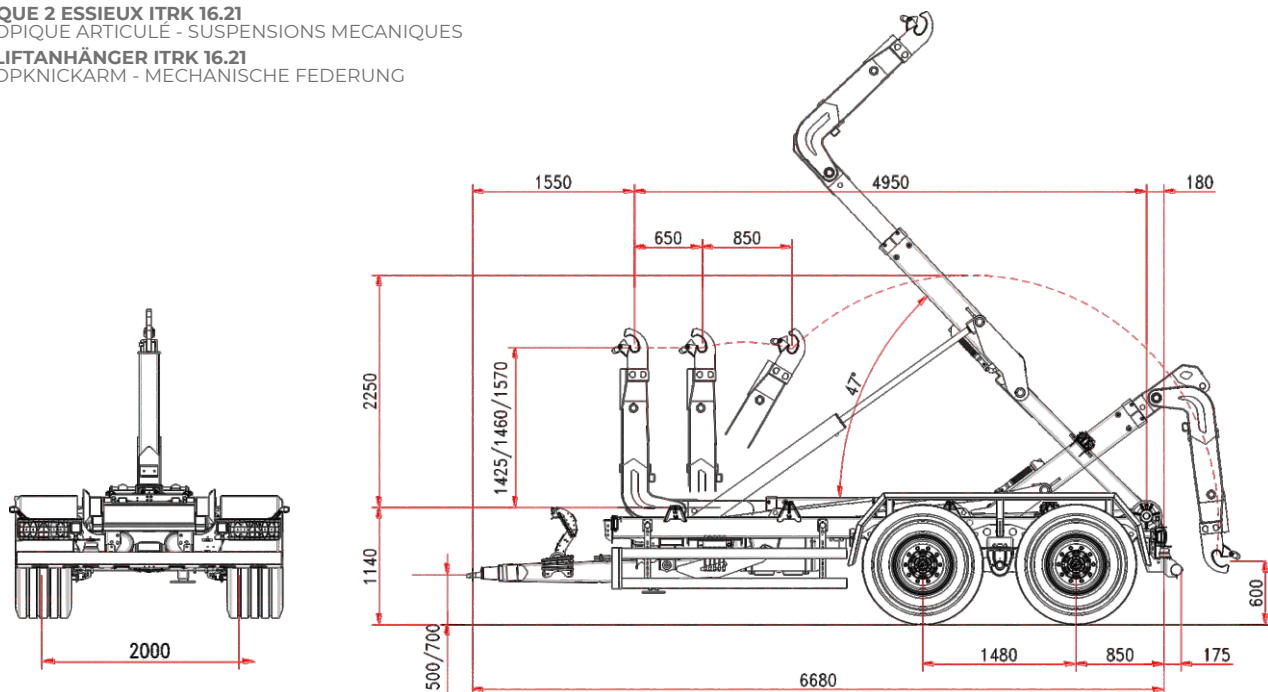

Caratteristiche Standard

Standard Features

Caractéristiques Standard

Standard-Merkmale

TELAIO

	Sezione longheroni	200 x 100 mm
	Sezioni assali	2 x 110 mm
	Freni a tamburo	400 x 80 mm
	Sezione ruote	500/60-22,5

PESO E MISURE

P.T.T. (G.T.W.)	21 t
Dimensione Min./Max cassone	4000/6000 mm
Max velocità	40 km/h
(*) Tara	4800 kg

BRACCIO TELESCOPICO ARTICOLATO

Altezza gancio	1425/1460/1570
Bloccaggio container esterno	idraulico
Angolo di ribaltamento	47°
Max cap. ribaltamento	16 t
Max cap. carico	16 t

SISTEMA IDRAULICO

Idraulica al trattore	1 elementi d.e.
-----------------------	-----------------

(*) la tara è riferita all'attrezzatura base del rimorchio senza opzioni ed accessori

CHASSIS

	Section structure	200 x 100 mm
	Section essieux	2 x 110 mm
	Freins tambour	400 x 80 mm
	Pneus	500/60-22,5

POIDS ET DIMENSIONS

Poids totale remorque	21 t
Longueur conteneur	4000/6000 mm
Max vitesse	40 km/h
(*) Tara	4800 kg

BRAS TELESCOPIQUE ARTICULÉ

Hauteur crochet	1425/1460/1570
Verrouillage conteneur	hydraulique
Angle de bennage	47°
Max capacité de bennage	16 t
Max capacité de charge	16 t

SYSTÈME HYDRAULIQUE

Hydraulique tracteur	1 contrôles d.e.
----------------------	------------------

(*) La tare de la remorque est référée à l'équipement base sans options et accessoires.

CHASSIS

	Frame section	200 x 100 mm
	Axles section	2 x 110 mm
	Brake drums	400 x 80 mm
	Wheel size	500/60-22,5

WEIGHT AND DIMENSION

Gross Trailer Weight (G.T.W.)	21 t
Container handling cap.	4000/6000 mm
Max speed	40 km/h
(*) Tare	4800 kg

TELESCOPIC ARTICULATED ARM

Hook level	1425/1460/1570
Container internal/external locking	hydraulic
Tipping angle	47°
Tipping capacity	16 t
Lifting capacity	16 t

OLEO-DYNAMIC SYSTEM

Tractor hydraulics	1 controls d. a.
--------------------	------------------

(*) Tare: the trailer weight is referred to the basic unit without options and accessories.

FAHRGESTELL

	Rahmenquerschnitt	200 x 100 mm
	Achsenquerschnitt	2 x 110 mm
	Bremstrommel	400 x 80 mm
	Bereifung	500/60-22,5

MASSE UND GEWICHT

Gesamtgewicht	21 t
Containerlänge min./max	4000/6000 mm
Zul.Höchstgeschwindigkeit	40 km/h
(*) Leergewicht	4800 kg

TELESKOPKNICK ARM

Hakenhöhe	1425/1460/1570
Innere/äußere Containerverriegelung	hydraulisch
Kippwinkel	47°
kippkapazität	16 t
Hebekapazität	16 t

HIDRAULIKANLAGE

Hydraulik am Traktor	1 doppelwirkende
----------------------	------------------

(*) Leergewicht ohne Zusatzausstattungen und Sonderausrüstungen



RIMORCHIO 2 ASSI ITRK 18.23
TELESCOPICO ARTICOLATO - SOSPENSIONI MECCANICHE
2 AXLES HOOKLIFT TRAILER ITRK 18.23
TELESCOPIC ARTICULATED - MECHANIC SUSPENSIONS
REMORQUE 2 ESSIEUX ITRK 18.23
TELESCOPIQUE ARTICULÉ - SUSPENSIONS MECANQUES
HAKENLIFTANHÄNGER ITRK 18.23
TELESKOPKNICKARM - MECHANISCHE FEDERUNG

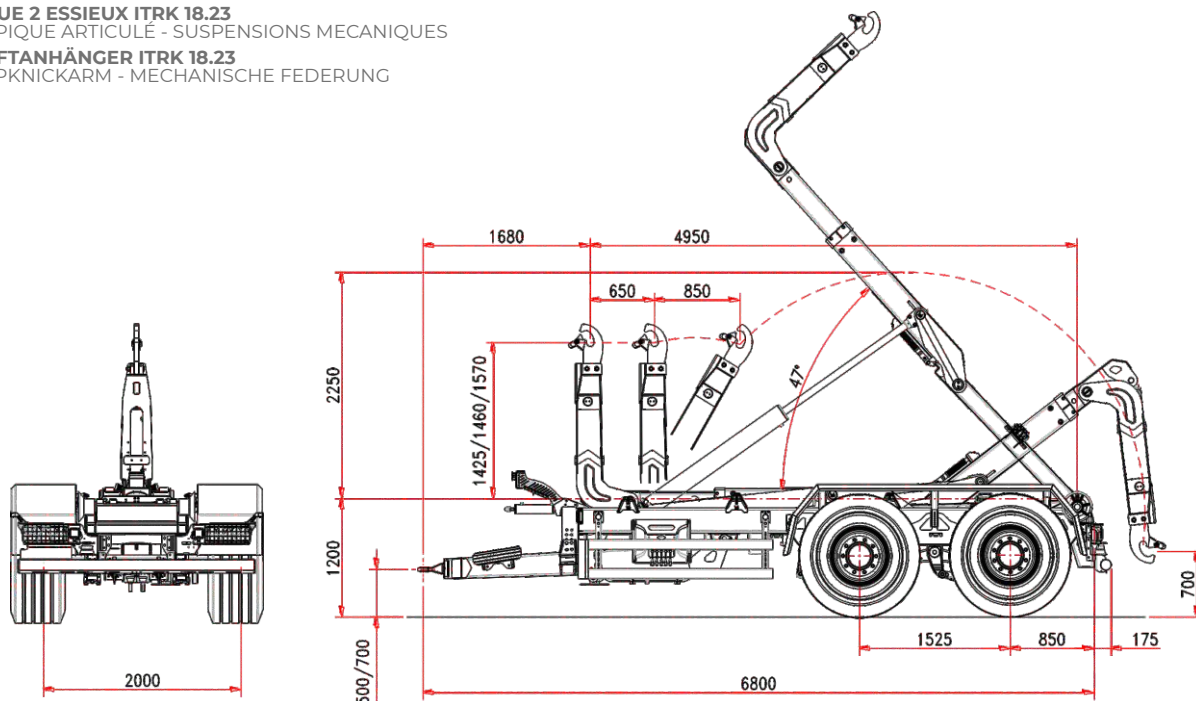

Caratteristiche Standard

Standard Features

Caractéristiques Standard

Standard-Merkmale

TELAIO

	Sezione longheroni	250 x 100 mm
	Sezioni assali	2 x 110 mm
	Freni a tamburo	406 x 120 mm
	Sezione ruote	550/60-22,5

PESO E MISURE

P.T.T. (G.T.W.)	23 t
Dimensione Min./Max cassone	4000/6000 mm
Max velocità	40 km/h
(*) Tara	5350 kg

BRACCIO TELESCOPICO ARTICOLATO

Altezza gancio	1425/1460/1570
Bloccaggio container esterno	idraulico
Angolo di ribaltamento	47°
Max cap. ribaltamento	18 t
Max cap. carico	18 t

SISTEMA IDRAULICO

Idraulica al trattore	2 elementi d.e.
-----------------------	-----------------

(*) la tara è riferita all'attrezzatura base del rimorchio senza opzioni ed accessori

CHASSIS

	Section structure	250 x 100 mm
	Section essieux	2 x 110 mm
	Freins tambour	406 x 120 mm
	Pneus	550/60-22,5

POIDS ET DIMENSIONS

Poids totale remorque	23 t
Longueur conteneur	4000/6000 mm
Max vitesse	40 km/h
(*) Tara	5350 kg

BRAS TELESCOPIQUE ARTICULÉ

Hauteur crochet	1425/1460/1570
Verrouillage conteneur	hydraulique
Angle de bennage	47°
Max capacité de bennage	18 t
Max capacité de charge	18 t

SYSTÈME HYDRAULIQUE

Hydraulique tracteur	2 contrôles d.e.
----------------------	------------------

(*) La tare de la remorque est référée à l'équipement base sans options et accessoires.

CHASSIS

	Frame section	250 x 100 mm
	Axles section	2 x 110 mm
	Brake drums	406 x 120 mm
	Wheel size	550/60-22,5

WEIGHT AND DIMENSION

Gross Trailer Weight (G.T.W.)	23 t
Container handling cap.	4000/6000 mm
Max speed	40 km/h
(*) Tare	5350 kg

TELESCOPIC ARTICULATED ARM

Hook level	1425/1460/1570
Container internal/external locking	hydraulic
Tipping angle	47°
Tipping capacity	18 t
Lifting capacity	18 t

OLEO-DYNAMIC SYSTEM

Tractor hydraulics	2 controls d. a.
--------------------	------------------

(*) Tare: the trailer weight is referred to the basic unit without options and accessories.

FAHRGESTELL

	Rahmenquerschnitt	250 x 100 mm
	Achsenquerschnitt	2 x 110 mm
	Bremstrommel	406 x 120 mm
	Bereifung	550/60-22,5

MASSE UND GEWICHT

Gesamtgewicht	23 t
Containerlänge min./max	4000/6000 mm
Zul.Höchstgeschwindigkeit	40 km/h
(*) Leergewicht	5350 kg

TELESKOPKNICK ARM

Hakenhöhe	1425/1460/1570
Innere/äußere Containerverriegelung	hydraulisch
Kippwinkel	47°
kippkapazität	18 t
Hebekapazität	18 t

HIDRAULIKANLAGE

Hydraulik am Traktor	2 doppelwirkende
----------------------	------------------

(*) Leergewicht ohne Zusatzausstattungen und Sonderausrüstungen



RIMORCHIO 2 ASSI ITRK 18.23 H
TELESCOPICO ARTICOLATO - SOSPENSIONI IDRAULICHE

2 AXLES HOOKLIFT TRAILER ITRK 18.23 H
TELESCOPIC ARTICULATED - HYDRAULICSUSPENSIONS

REMORQUE 2 ESSIEUX ITRK 18.23 H
TELESCOPIQUE ARTICULÉ - SUSPENSIONS HYDRAULIQUES

HAKENLIFTANHÄNGER ITRK 18.23 H
TELESKOPKNICKARM - HYDRAULISCH FEDERUNG

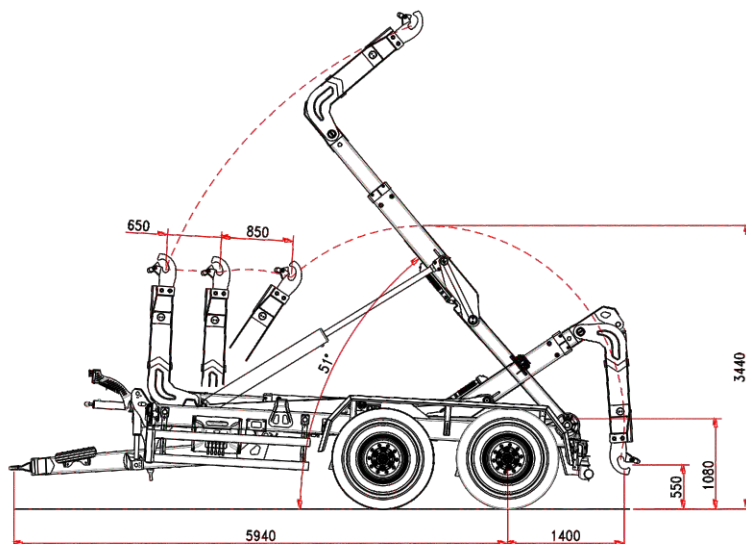
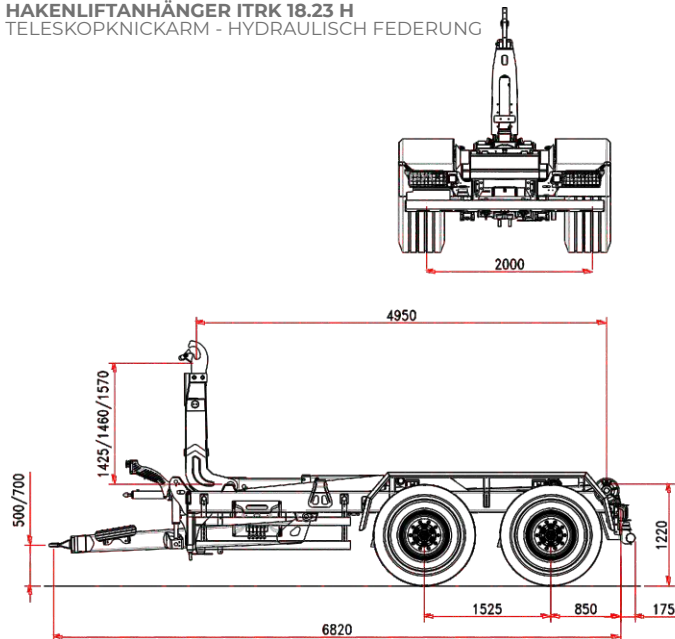

Caratteristiche Standard

Standard Features

Caractéristiques Standard

Standard-Merkmale

TELAIO

	Sezione longheroni	250 x 100 mm
	Sezioni assali	2 x 150 mm
	Freni a tamburo	406 x 120 mm
	Sezione ruote	550/60-22,5

PESO E MISURE

P.T.T. (G.T.W.)	23 t
Dimensione Min./Max cassone	4000/6000 mm
Max velocità	40 km/h
(*) Tara	5450 kg

BRACCIO TELESCOPICO ARTICOLATO

Altezza gancio	1425/1460/1570
Bloccaggio container esterno	idraulico
Angolo di ribaltamento	51°
Max cap. ribaltamento	18 t
Max cap. carico	18 t

SISTEMA IDRAULICO

Idraulica al trattore	4 elementi d.e.
-----------------------	-----------------

(*) la tara è riferita all'attrezzatura base del rimorchio senza opzioni ed accessori

CHASSIS

	Section structure	250 x 100 mm
	Section essieux	2 x 150 mm
	Freins tambour	406 x 120 mm
	Pneus	550/60-22,5

POIDS ET DIMENSIONS

Poids totale remorque	23 t
Longueur conteneur	4000/6000 mm
Max vitesse	40 km/h
(*) Tara	5450 kg

BRAS TELESCOPIQUE ARTICULÉ

Hauteur crochet	1425/1460/1570
Verrouillage conteneur	hydraulique
Angle de bennage	51°
Max capacité de bennage	18 t
Max capacité de charge	18 t

SYSTÈME HYDRAULIQUE

Hydraulique tracteur	4 contrôles d.e.
----------------------	------------------

(*) La tare de la remorque est référée à l'équipement base sans options et accessoires.

CHASSIS

	Frame section	250 x 100 mm
	Axles section	2 x 150 mm
	Brake drums	406 x 120 mm
	Wheel size	550/60-22,5

WEIGHT AND DIMENSION

Gross Trailer Weight (G.T.W.)	23 t
Container handling cap.	4000/6000 mm
Max speed	40 km/h
(*) Tare	5450 kg

TELESCOPIC ARTICULATED ARM

Hook level	1425/1460/1570
Container internal/external locking	hydraulic
Tipping angle	51°
Tipping capacity	18 t
Lifting capacity	18 t

OLEO-DYNAMIC SYSTEM

Tractor hydraulics	4 controls d. a.
--------------------	------------------

(*) Tare: the trailer weight is referred to the basic unit without options and accessories.

FAHRGESTELL

	Rahmenquerschnitt	250 x 100 mm
	Achsenquerschnitt	2 x 150 mm
	Bremstrommel	406 x 120 mm
	Bereifung	550/60-22,5

MASSE UND GEWICHT

Gesamtgewicht	23 t
Containerlänge min./max	4000/6000 mm
Zul.Höchstgeschwindigkeit	40 km/h
(*) Leergewicht	5450 kg

TELESKOPKNICK ARM

Hakenhöhe	1425/1460/1570
Innere/äußere Containerverriegelung	hydraulisch
Kippwinkel	51°
kippkapazität	18 t
Hebekapazität	18 t

HIDRAULIKANLAGE

Hydraulik am Traktor	4 doppelwirkende Steuerelemente
----------------------	---------------------------------

(*) Leergewicht ohne Zusatzausstattungen und Sonderausrüstungen



RIMORCHIO 2 ASSI ITRK 22.23 X
TELESCOPICO ARTICOLATO - SOSPENSIONI IDRAULICHE

2 AXLES HOOKLIFT TRAILER ITRK 22.23 X
TELESCOPIC ARTICULATED - HYDRAULICSUSPENSIONS

REMORQUE 2 ESSIEUX ITRK 22.23 X
TELESCOPIQUE ARTICULÉ - SUSPENSIONS HYDRAULIQUES

HAKENLIFTANHÄNGER ITRK 22.23 X
TELESKOPKNICKARM - HYDRAULISCH FEDERUNG

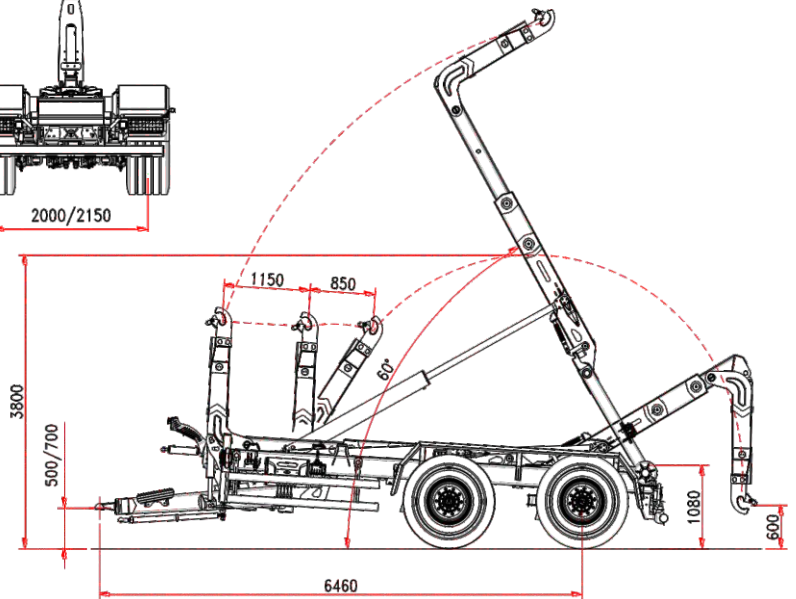
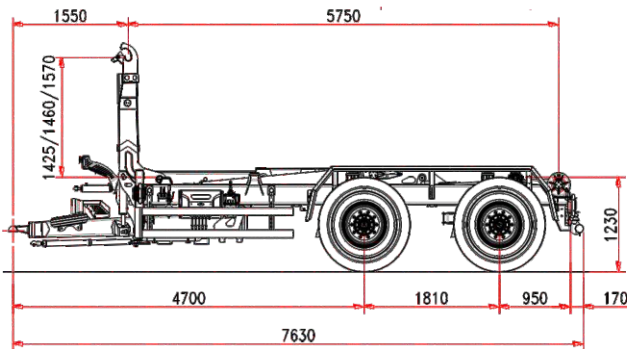
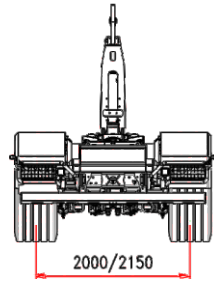

Caratteristiche Standard

Standard Features

Caractéristiques Standard

Standard-Merkmale

TELAIO

	Sezione longheroni	250 x 100 mm
	Sezioni assali	2 x 150 mm
	Freni a tamburo	406 x 120 mm
	Sezione ruote	550/60-22,5

PESO E MISURE

P.T.T. (G.T.W.)	23 t
Dimensione Min./Max cassone	4500/6500 mm
Max velocità	40 km/h
(*) Tara	6300 kg

BRACCIO TELESCOPICO ARTICOLATO

Altezza gancio	1425/1460/1570
Bloccaggio container esterno	idraulico
Angolo di ribaltamento	60°
Max cap. ribaltamento	22 t
Max cap. carico	22 t

SISTEMA IDRAULICO

Idraulica al trattore	4 elementi d.e.
-----------------------	-----------------

(*) la tara è riferita all'attrezzatura base del rimorchio senza opzioni ed accessori

CHASSIS

	Section structure	250 x 100 mm
	Section essieux	2 x 150 mm
	Freins tambour	406 x 120 mm
	Pneus	550/60-22,5

POIDS ET DIMENSIONS

Poids totale remorque	23 t
Longueur conteneur	4500/6500 mm
Max vitesse	40 km/h
(*) Tara	6300 kg

BRAS TELESCOPIQUE ARTICULÉ

Hauteur crochet	1425/1460/1570
Verrouillage conteneur	hydraulique
Angle de bennage	60°
Max capacité de bennage	22 t
Max capacité de charge	22 t

SYSTÈME HYDRAULIQUE

Hydraulique tracteur	4 contrôles d.e.
----------------------	------------------

(*) La tare de la remorque est référée à l'équipement base sans options et accessoires.

CHASSIS

	Frame section	250 x 100 mm
	Axles section	2 x 150 mm
	Brake drums	406 x 120 mm
	Wheel size	550/60-22,5

WEIGHT AND DIMENSION

Gross Trailer Weight (G.T.W.)	23 t
Container handling cap.	4500/6500 mm
Max speed	40 km/h
(*) Tare	6300 kg

TELESCOPIC ARTICULATED ARM

Hook level	1425/1460/1570
Container internal/external locking	hydraulic
Tipping angle	60°
Tipping capacity	22 t
Lifting capacity	22 t

OLEO-DYNAMIC SYSTEM

Tractor hydraulics	4 controls d. a.
--------------------	------------------

(*) Tare: the trailer weight is referred to the basic unit without options and accessories.

FAHRGESTELL

	Rahmenquerschnitt	250 x 100 mm
	Achsenquerschnitt	2 x 150 mm
	Bremstrommel	406 x 120 mm
	Bereifung	550/60-22,5

MASSE UND GEWICHT

Gesamtgewicht	23 t
Containerlänge min./max	4500/6500 mm
Zul.Höchstgeschwindigkeit	40 km/h
(*) Leergewicht	6300 kg

TELESKOPKNICK ARM

Hakenhöhe	1425/1460/1570
Innere/äußere Containerverriegelung	hydraulisch
Kippwinkel	60°
kippkapazität	22 t
Hebekapazität	22 t

HIDRAULIKANLAGE

Hydraulik am Traktor	4 doppelwirkende
----------------------	------------------

(*) Leergewicht ohne Zusatzausstattungen und Sonderausrüstungen



RIMORCHIO 2 ASSI ITRK 22.23 X7
TELESCOPICO ARTICOLATO - SOSPENSIONI IDRAULICHE

2 AXLES HOOKLIFT TRAILER ITRK 22.23 X7
TELESCOPIC ARTICULATED - HYDRAULICSUSPENSIONS

REMORQUE 2 ESSIEUX ITRK 22.23 X7
TELESCOPIQUE ARTICULÉ - SUSPENSIONS HYDRAULIQUES

HAKENLIFTANHÄNGER ITRK 22.23 X7
TELESKOPKNICKARM - HYDRAULISCH FEDERUNG

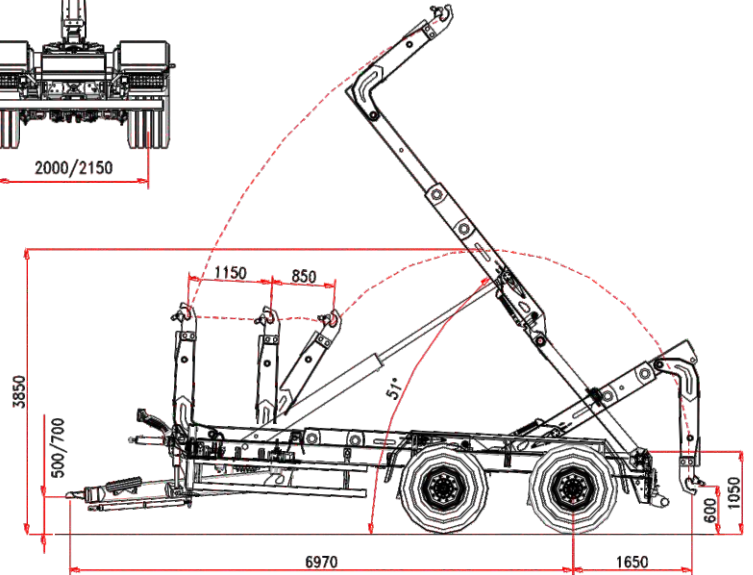
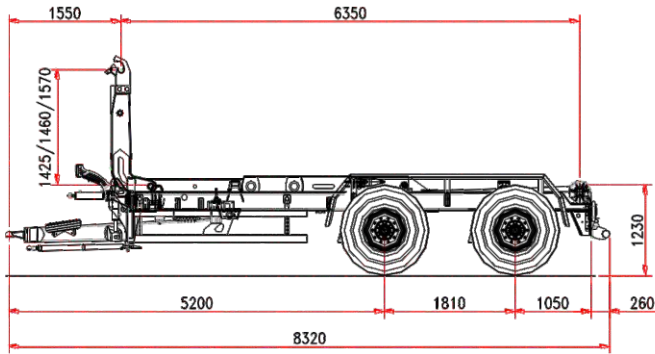
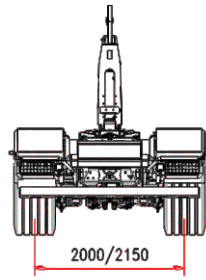

Caratteristiche Standard

Standard Features

Caractéristiques Standard

Standard-Merkmale

TELAIO

	Sezione longheroni	250 x 100 mm
	Sezioni assali	2 x 150 mm
	Freni a tamburo	406 x 120 mm
	Sezione ruote	550/60-22,5

PESO E MISURE

P.T.T. (G.T.W.)	23 t
Dimensione Min./Max cassone	5000/7200 mm
Max velocità	40 km/h
(*) Tara	6350 kg

BRACCIO TELESCOPICO ARTICOLATO

Altezza gancio	1425/1460/1570
Bloccaggio container esterno	idraulico
Angolo di ribaltamento	51°
Max cap. ribaltamento	22 t
Max cap. carico	22 t

SISTEMA IDRAULICO

Idraulica al trattore	4 elementi d.e.
-----------------------	-----------------

(*) la tara è riferita all'attrezzatura base del rimorchio senza opzioni ed accessori

CHASSIS

	Section structure	250 x 100 mm
	Section essieux	2 x 150 mm
	Freins tambour	406 x 120 mm
	Pneus	550/60-22,5

POIDS ET DIMENSIONS

Poids totale remorque	23 t
Longueur conteneur	5000/7200 mm
Max vitesse	40 km/h
(*) Tara	6350 kg

BRAS TELESCOPIQUE ARTICULÉ

Hauteur crochet	1425/1460/1570
Verrouillage conteneur	hydraulique
Angle de bennage	51°
Max capacité de bennage	22 t
Max capacité de charge	22 t

SYSTÈME HYDRAULIQUE

Hydraulique tracteur	4 contrôles d.e.
----------------------	------------------

(*) La tare de la remorque est référée à l'équipement base sans options et accessoires.

CHASSIS

	Frame section	250 x 100 mm
	Axles section	2 x 150 mm
	Brake drums	406 x 120 mm
	Wheel size	550/60-22,5

WEIGHT AND DIMENSION

Gross Trailer Weight (G.T.W.)	23 t
Container handling cap.	5000/7200 mm
Max speed	40 km/h
(*) Tare	6350 kg

TELESCOPIC ARTICULATED ARM

Hook level	1425/1460/1570
Container internal/external locking	hydraulic
Tipping angle	51°
Tipping capacity	22 t
Lifting capacity	22 t

OLEO-DYNAMIC SYSTEM

Tractor hydraulics	4 controls d. a.
--------------------	------------------

(*) Tare: the trailer weight is referred to the basic unit without options and accessories.

FAHRGESTELL

	Rahmenquerschnitt	250 x 100 mm
	Achsenquerschnitt	2 x 150 mm
	Bremstrommel	406 x 120 mm
	Bereifung	550/60-22,5

MASSE UND GEWICHT

Gesamtgewicht	23 t
Containerlänge min./max	5000/7200 mm
Zul.Höchstgeschwindigkeit	40 km/h
(*) Leergewicht	6350 kg

KNICKTELESCOP ARM

Hakenhöhe	1425/1460/1570
Innere/äußere Containerverriegelung	hydraulisch
Kippwinkel	51°
kippkapazität	22 t
Hebekapazität	22 t

HIDRAULIKANLAGE

Hydraulik am Traktor	4 doppelwirkende Steuerelemente
----------------------	---------------------------------

(*) Leergewicht ohne Zusatzausstattungen und Sonderausrüstungen



RIMORCHIO 3 ASSI ITRK 22.33 X
TELESCOPICO ARTICOLATO - SOSPENSIONI IDRAULICHE

3 AXLES HOOKLIFT TRAILER ITRK 22.33 X
TELESCOPIC ARTICULATED - HYDRAULICSUSPENSIONS

REMORQUE 3 ESSIEUX ITRK 22.33 X
TELESCOPIQUE ARTICULÉ - SUSPENSIONSHYDRAULIQUES

HAKENLIFTANHÄNGER ITRK 22.33 X
TELESKOPKNICKARM - HYDRAULISCH FEDERUNG

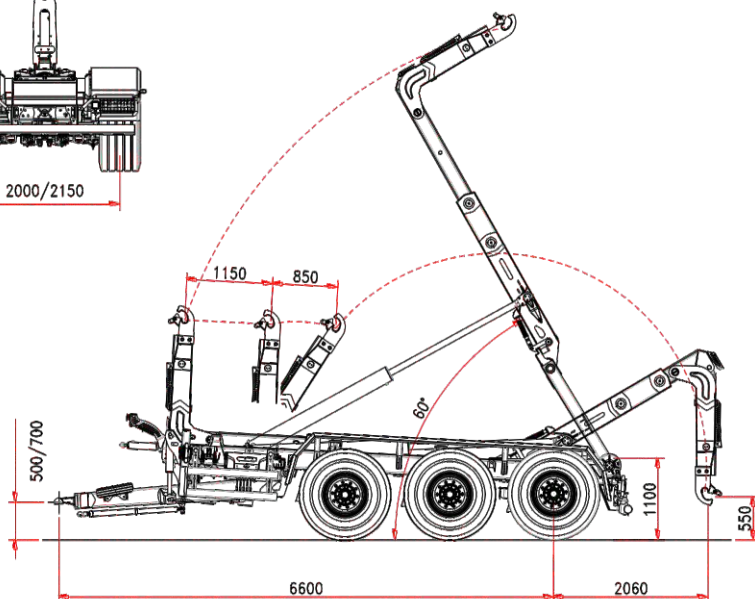
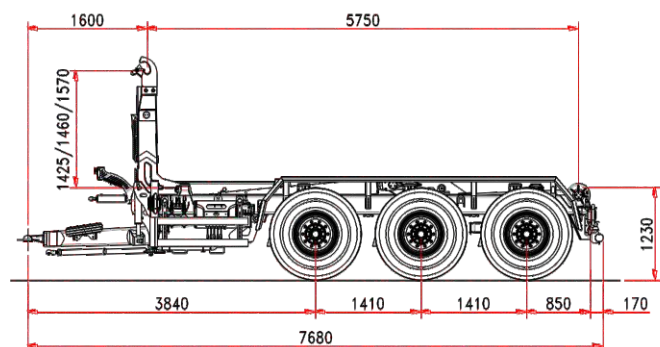
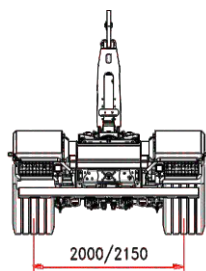

Caratteristiche Standard

Standard Features

Caractéristiques Standard

Standard-Merkmale

TELAIO

	Sezione longheroni	250 x 100 mm
	Sezioni assali	3 x 150 mm
	Freni a tamburo	406 x 120 mm
	Sezione ruote	550/60-22,5

PESO E MISURE

P.T.T. (G.T.W.)	33 t
Dimensione Min./Max cassone	4500/6500 mm
Max velocità	40 km/h
(*) Tara	7400 kg

BRACCIO TELESCOPICO ARTICOLATO

Altezza gancio	1425/1460/1570
Bloccaggio container esterno	idraulico
Angolo di ribaltamento	60°
Max cap. ribaltamento	22 t
Max cap. carico	22 t

SISTEMA IDRAULICO

Idraulica al trattore	4 elementi d.e.
-----------------------	-----------------

(*) la tara è riferita all'attrezzatura base del rimorchio senza opzioni ed accessori

CHASSIS

	Section structure	250 x 100 mm
	Section essieux	3 x 150 mm
	Freins tambour	406 x 120 mm
	Pneus	550/60-22,5

POIDS ET DIMENSIONS

Poids totale remorque	33 t
Longueur conteneur	4500/6500 mm
Max vitesse	40 km/h
(*) Tara	7400 kg

BRAS TELESCOPIQUE ARTICULÉ

Hauteur crochet	1425/1460/1570
Verrouillage conteneur	hydraulique
Angle de bennage	60°
Max capacité de bennage	22 t
Max capacité de charge	22 t

SYSTÈME HYDRAULIQUE

Hydraulique tracteur	4 contrôles d.e.
----------------------	------------------

(*) La tare de la remorque est référencé à l'équipement base sans options et accessoires.

CHASSIS

	Frame section	250 x 100 mm
	Axles section	3 x 150 mm
	Brake drums	406 x 120 mm
	Wheel size	550/60-22,5

WEIGHT AND DIMENSION

Gross Trailer Weight (G.T.W.)	33 t
Container handling cap.	4500/6500 mm
Max speed	40 km/h
(*) Tare	7400 kg

TELESCOPIC ARTICULATED ARM

Hook level	1425/1460/1570
Container internal/external locking	hydraulic
Tipping angle	60°
Tipping capacity	22 t
Lifting capacity	22 t

OLEO-DYNAMIC SYSTEM

Tractor hydraulics	4 controls d. a.
--------------------	------------------

(*) Tare: the trailer weight is referred to the basic unit without options and accessories.

FAHRGESTELL

	Rahmenquerschnitt	250 x 100 mm
	Achsenquerschnitt	3 x 150 mm
	Bremstrommel	406 x 120 mm
	Bereifung	550/60-22,5

MASSE UND GEWICHT

Gesamtgewicht	33 t
Containerlänge min./max	4500/6500 mm
Zul.Höchstgeschwindigkeit	40 km/h
(*) Leergewicht	7400 kg

KNICKTELESCOP ARM

Hakenhöhe	1425/1460/1570
Innere/äußere Containerverriegelung	hydraulisch
Kippwinkel	60°
kippkapazität	22 t
Hebekapazität	22 t

HIDRAULIKANLAGE

Hydraulik am Traktor	4 doppelwirkende Steuerelemente
----------------------	---------------------------------

(*) Leergewicht ohne Zusatzausstattungen und Sonderausrüstungen



RIMORCHIO 3 ASSI ITRK 22.33 X7
TELESCOPICO ARTICOLATO - SOSPENSIONI IDRAULICHE

3 AXLES HOOKLIFT TRAILER ITRK 22.33 X7
TELESCOPIC ARTICULATED - HYDRAULICSUSPENSIONS

REMORQUE 3 ESSIEUX ITRK 22.33 X7
TELESCOPIQUE ARTICULÉ - SUSPENSIONSHYDRAULIQUES

HAKENLIFTANHÄNGER ITRK 22.33 X7
TELESKOPKNICKARM - HYDRAULISCH FEDERUNG

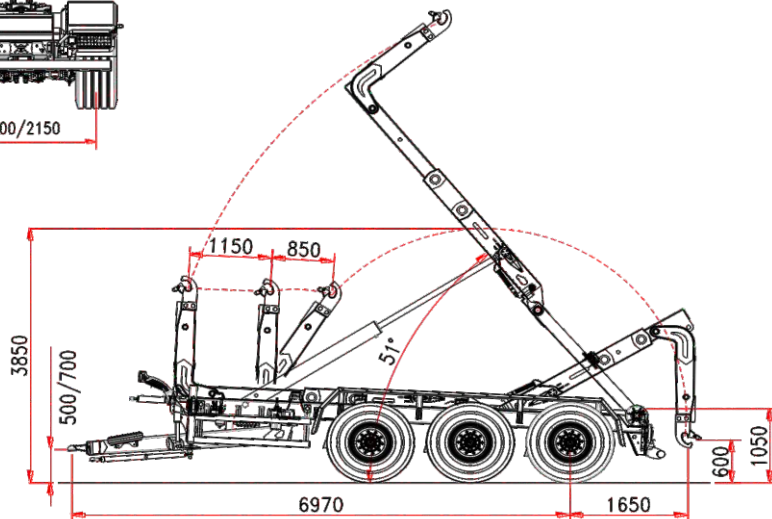
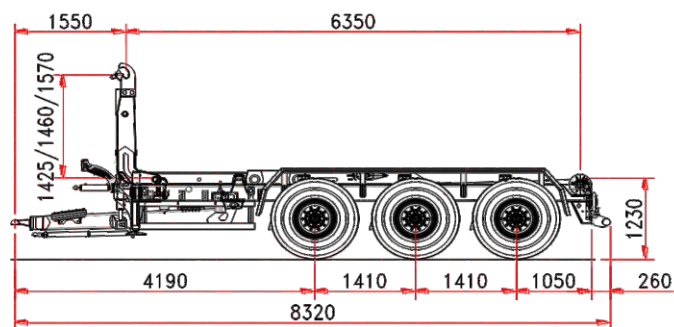
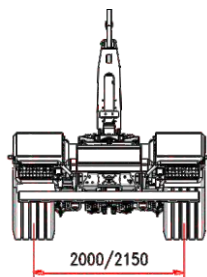

Caratteristiche Standard

Standard Features

Caractéristiques Standard

Standard-Merkmale

TELAIO

	Sezione longheroni	250 x 100 mm
	Sezioni assali	3 x 150 mm
	Freni a tamburo	406 x 120 mm
	Sezione ruote	550/60-22,5

PESO E MISURE

P.T.T. (G.T.W.)	33 t
Dimensione Min./Max cassone	5000/7200 mm
Max velocità	40 km/h
(*) Tara	7400 kg

BRACCIO TELESCOPICO ARTICOLATO

Altezza gancio	1425/1460/1570
Bloccaggio container esterno	idraulico
Angolo di ribaltamento	51°
Max cap. ribaltamento	22 t
Max cap. carico	22 t

SISTEMA IDRAULICO

Idraulica al trattore	4 elementi d.e.
-----------------------	-----------------

(*) la tara è riferita all'attrezzatura base del rimorchio senza opzioni ed accessori

CHASSIS

	Section structure	250 x 100 mm
	Section essieux	3 x 150 mm
	Freins tambour	406 x 120 mm
	Pneus	550/60-22,5

POIDS ET DIMENSIONS

Poids totale remorque	33 t
Longueur conteneur	5000/7200 mm
Max vitesse	40 km/h
(*) Tara	7400 kg

BRAS TELESCOPIQUE ARTICULÉ

Hauteur crochet	1425/1460/1570
Verrouillage conteneur	hydraulique
Angle de bennage	51°
Max capacité de bennage	22 t
Max capacité de charge	22 t

SYSTÈME HYDRAULIQUE

Hydraulique tracteur	4 contrôles d.e.
----------------------	------------------

(*) La tare de la remorque est référée à l'équipement base sans options et accessoires.

CHASSIS

	Frame section	250 x 100 mm
	Axles section	3 x 150 mm
	Brake drums	406 x 120 mm
	Wheel size	550/60-22,5

WEIGHT AND DIMENSION

Gross Trailer Weight (G.T.W.)	33 t
Container handling cap.	5000/7200 mm
Max speed	40 km/h
(*) Tare	7400 kg

TELESCOPIC ARTICULATED ARM

Hook level	1425/1460/1570
Container internal/external locking	hydraulic
Tipping angle	51°
Tipping capacity	22 t
Lifting capacity	22 t

OLEO-DYNAMIC SYSTEM

Tractor hydraulics	4 controls d. a.
--------------------	------------------

(*) Tare: the trailer weight is referred to the basic unit without options and accessories.

FAHRGESTELL

	Rahmenquerschnitt	250 x 100 mm
	Achsenquerschnitt	3 x 150 mm
	Bremstrommel	406 x 120 mm
	Bereifung	550/60-22,5

MASSE UND GEWICHT

Gesamtgewicht	33 t
Containerlänge min./max	5000/7200 mm
Zul.Höchstgeschwindigkeit	40 km/h
(*) Leergewicht	7400 kg

TELESKOPKNICK ARM

Hakenhöhe	1425/1460/1570
Innere/äußere Containerverriegelung	hydraulisch
Kippwinkel	51°
kippkapazität	22 t
Hebekapazität	22 t

HIDRAULIKANLAGE

Hydraulik am Traktor	4 doppelwirkende Steuerelemente
----------------------	---------------------------------

(*) Leergewicht ohne Zusatzausstattungen und Sonderausrüstungen





RIMORCHIO 3 ASSI ITRK 26.33 HD
TELESCOPICO ARTICOLATO - SOSPENSIONI IDRAULICHE

3 AXLES HOOKLIFT TRAILER ITRK 26.33 HD
TELESCOPIC ARTICULATED - HYDRAULICSUSPENSIONS

REMORQUE 3 ESSIEUX ITRK 26.33 HD
TELESCOPIQUE ARTICULÉ - SUSPENSIONSHYDRAULIQUES

HAKENLIFTANHÄNGER ITRK 26.33 HD
TELESKOPKNICKARM - HYDRAULISCH FEDERUNG

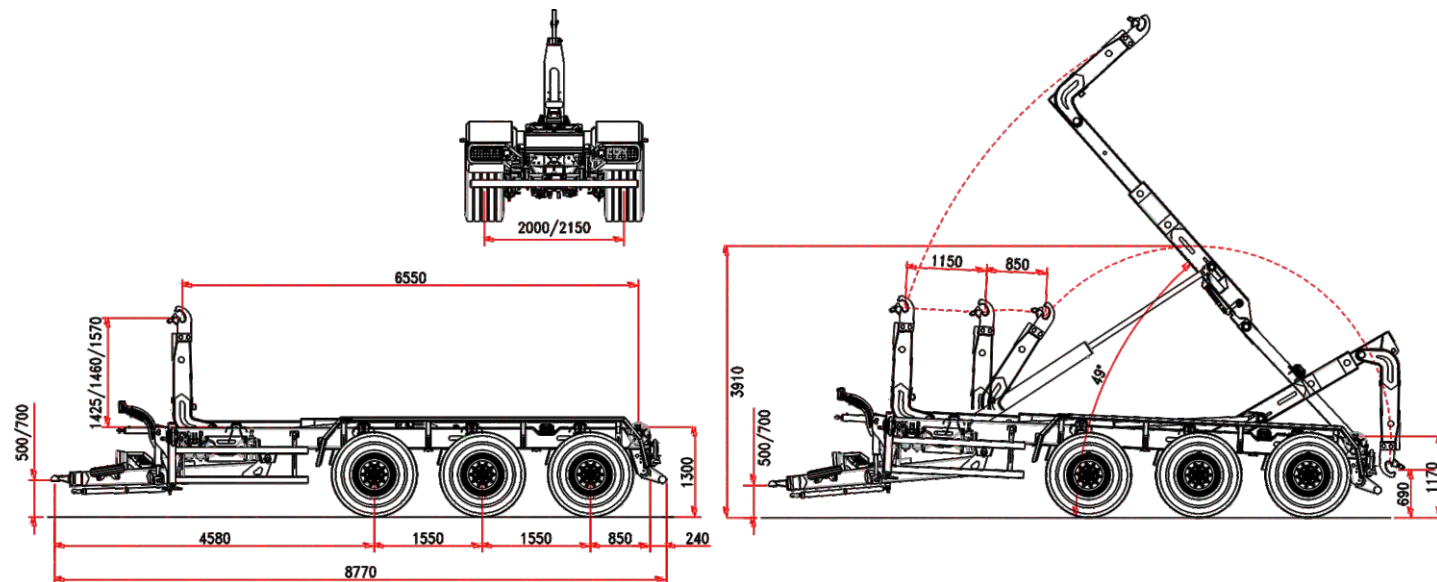

Caratteristiche Standard

Standard Features

Caractéristiques Standard

Standard-Merkmale

TELAIO

Sezione longheroni	250 x 100 mm
Sezioni assali	3 x 150 mm
Freni a tamburo	406 x 120 mm
Sezione ruote	550/60-22,5

PESO E MISURE

P.T.T. (G.T.W.)	33 t
Dimensione Min./Max cassone	5000/7500 mm
Max velocità	40 km/h
(*) Tara	7950 kg

BRACCIO TELESCOPICO ARTICOLATO

Altezza gancio	1425/1460/1570
Bloccaggio container esterno	idraulico
Angolo di ribaltamento	49°
Max cap. ribaltamento	26 t
Max cap. carico	26 t

SISTEMA IDRAULICO

Idraulica al trattore	3 elementi d.e.
-----------------------	-----------------

(*) la tara è riferita all'attrezzatura base del rimorchio senza opzioni ed accessori

CHASSIS

Section structure	250 x 100 mm
Section essieux	3 x 150 mm
Freins tambour	406 x 120 mm
Pneus	550/60-22,5

POIDS ET DIMENSIONS

Poids totale remorque	33 t
Longueur conteneur	5000/7500 mm
Max vitesse	40 km/h
(*) Tara	7950 kg

BRAS TELESCOPIQUE ARTICULÉ

Hauteur crochet	1425/1460/1570
Verrouillage conteneur	hydraulique
Angle de bennage	49°
Max capacité de bennage	26 t
Max capacité de charge	26 t

SYSTÈME HYDRAULIQUE

Hydraulique tracteur	3 contrôles d.e.
----------------------	------------------

(*) La tare de la remorque est référée à l'équipement base sans options et accessoires.

CHASSIS

Frame section	250 x 100 mm
Axles section	3 x 150 mm
Brake drums	406 x 120 mm
Wheel size	550/60-22,5

WEIGHT AND DIMENSION

Gross Trailer Weight (G.T.W.)	33 t
Container handling cap.	5000/7500 mm
Max speed	40 km/h
(*) Tare	7950 kg

TELESCOPIC ARTICULATED ARM

Hook level	1425/1460/1570
Container internal/external locking	hydraulic
Tipping angle	49°
Tipping capacity	26 t
Lifting capacity	26 t

OLEO-DYNAMIC SYSTEM

Tractor hydraulics	3 controls d. a.
--------------------	------------------

(*) Tare: the trailer weight is referred to the basic unit without options and accessories.

FAHRGESTELL

Rahmenquerschnitt	250 x 100 mm
Achsenquerschnitt	3 x 150 mm
Bremstrommel	406 x 120 mm
Bereifung	550/60-22,5

MASSE UND GEWICHT

Gesamtgewicht	33 t
Containerlänge min./max	5000/7500 mm
Zul.Höchstgeschwindigkeit	40 km/h
(*) Leergewicht	7950 kg

TELESKOPKNICK ARM

Hakenhöhe	1425/1460/1570
Innere/äußere Containerverriegelung	hydraulisch
Kippwinkel	49°
kippkapazität	26 t
Hebekapazität	26 t

HIDRAULIKANLAGE

Hydraulik am Traktor	3 doppelwirkende Steuerelemente
----------------------	---------------------------------

(*) Leergewicht ohne Zusatzausstattungen und Sonderausrüstungen



RIMORCHIO 3 ASSI ITRK 30.34 HD
TELESCOPICO ARTICOLATO - SOSPENSIONI IDRAULICHE

3 AXLES HOOKLIFT TRAILER ITRK 30.34 HD
TELESCOPIC ARTICULATED - HYDRAULICSUSPENSIONS

REMORQUE 3 ESSIEUX ITRK 30.34 HD
TELESCOPIQUE ARTICULÉ - SUSPENSIONSHYDRAULIQUES

HAKENLIFTANHÄNGER ITRK 30.34 HD
TELESKOPKNICKARM - HYDRAULISCH FEDERUNG

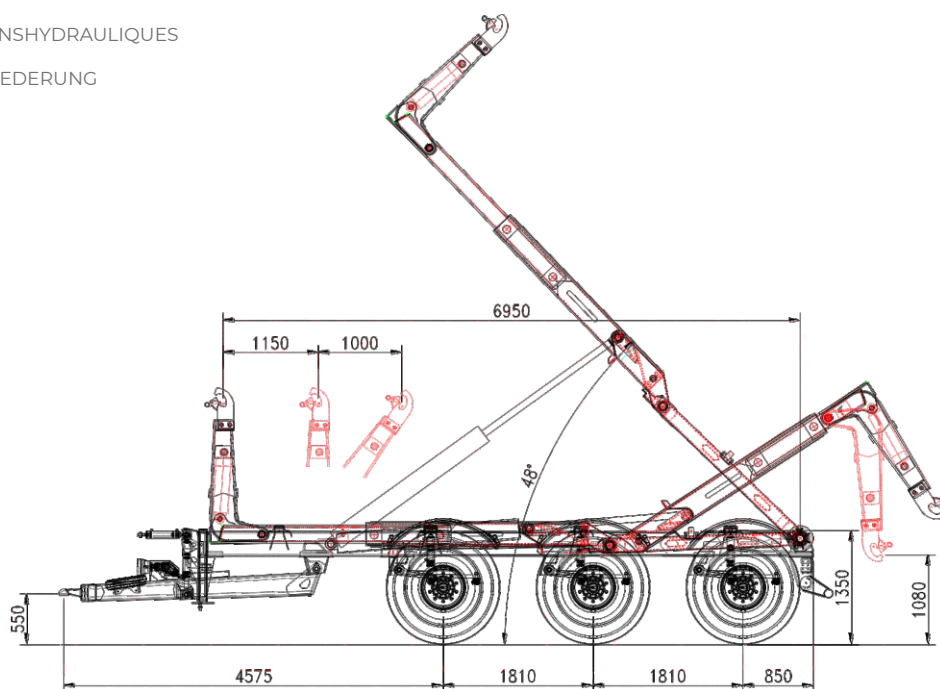
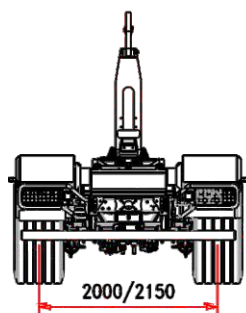

Caratteristiche Standard

Standard Features

Caractéristiques Standard

Standard-Merkmale

TELAIO

	Sezione longheroni	300 x 100 mm
	Sezioni assali	3 x 150 mm
	Freni a tamburo	406 x 120 mm
	Sezione ruote	550/60-22,5

PESO E MISURE

P.T.T. (G.T.W.)	33/34 t
Dimensione Min./Max cassone	5500/8200 mm
Max velocità	40 km/h
(*) Tara	8600 kg

BRACCIO TELESCOPICO ARTICOLATO

Altezza gancio	1425/1460/1570
Bloccaggio container esterno	idraulico
Angolo di ribaltamento	48°
Max cap. ribaltamento	30 t
Max cap. carico	30 t

SISTEMA IDRAULICO

Idraulica al trattore	3 elementi d.e.
-----------------------	-----------------

(*) la tara è riferita all'attrezzatura base del rimorchio senza opzioni ed accessori

CHASSIS

	Section structure	300 x 100 mm
	Section essieux	3 x 150 mm
	Freins tambour	406 x 120 mm
	Pneus	550/60-22,5

POIDS ET DIMENSIONS

Poids totale remorque	33/34 t
Longueur conteneur	5500/8200 mm
Max vitesse	40 km/h
(*) Tara	8600 kg

BRAS TELESCOPIQUE ARTICULÉ

Hauteur crochet	1425/1460/1570
Verrouillage conteneur	hydraulique
Angle de bennage	48°
Max capacité de bennage	30 t
Max capacité de charge	30 t

SYSTÈME HYDRAULIQUE

Hydraulique tracteur	3 contrôles d.e.
----------------------	------------------

(*) La tare de la remorque est référencé à l'équipement base sans options et accessoires.

CHASSIS

	Frame section	300 x 100 mm
	Axles section	3 x 150 mm
	Brake drums	406 x 120 mm
	Wheel size	550/60-22,5

WEIGHT AND DIMENSION

Gross Trailer Weight (G.T.W.)	33/34 t
Container handling cap.	5500/8200 mm
Max speed	40 km/h
(*) Tare	8600 kg

TELESCOPIC ARTICULATED ARM

Hook level	1425/1460/1570
Container internal/external locking	hydraulic
Tipping angle	48°
Tipping capacity	30 t
Lifting capacity	30 t

OLEO-DYNAMIC SYSTEM

Tractor hydraulics	3 controls d. a.
--------------------	------------------

(*) Tare: the trailer weight is referred to the basic unit without options and accessories.

FAHRGESTELL

	Rahmenquerschnitt	300 x 100 mm
	Achsenquerschnitt	3 x 150 mm
	Bremstrommel	406 x 120 mm
	Bereifung	550/60-22,5

MASSE UND GEWICHT

Gesamtgewicht	33/34 t
Containerlänge min./max	5500/8200 mm
Zul.Höchstgeschwindigkeit	40 km/h
(*) Leergewicht	8600 kg

TELESKOPKNICK ARM

Hakenhöhe	1425/1460/1570
Innere/äußere Containerverriegelung	hydraulisch
Kippwinkel	48°
kippkapazität	30 t
Hebekapazität	30 t

HIDRAULIKANLAGE

Hydraulik am Traktor	3 doppelwirkende Steuerelemente
----------------------	---------------------------------

(*) Leergewicht ohne Zusatzausstattungen und Sonderausrüstungen

www.itrunner.it

ITRunner



ITRunner

Reg. Oltre Rea, 32
12060 Monchiero (CN) - Italy
Phone +39 0173 780 002
Email: info@itrunner.it



lift your life

